

SEETRONIC

Product Data Sheet

Product Type

LED Flood Light

Product Model

G7KA1*

Customer Name

Manufacturer	Prepared	Checked	Approved

Customer	Received	Checked	Confirmed

Distributor:



Phone: 407-857-8770

Fax: 407-857-8771

Email: sales@techni-lux.com

www.techni-lux.com



Product Data Sheet

Product Type	IP67 XLR Plug	
Product Model	SCWM3-67	

Product Features

- 3-core waterproof XLR male cable connector with chrome plated housing and gold plated contacts
- Durable and ruggedly sealed XLR connector used for outdoor conditions with protection grade IP67
- Rugged zinc die-cast shell for long life and high reliability
- The metal housing is designed with internal threads to ensure that it can withstand gravity pressure under any site conditions
- The boot is equipped with a polyurethane sealing sleeve to prevent the cable from bending pressure to the greatest extent.

Product Data Sheet

Product Parameters

Item	Specification
Connection Type	XLR
Gender	Male

Electrical Parameters

Item	Specification
Capacitance between contacts	≤ 4 pF
Contact resistance	≤ 3 m Ω
Dielectric strength	1.5 kV DC
Insulation resistance	> 10 G Ω (initial)
Rated current per contact	16 A
Rated voltage	< 50 V

Product Data Sheet

Mechanical Parameters

Item	Specification
Cable O.D.	5-8 mm
Insertion force	≤ 20 N
Withdrawal force	≤ 20 N
Service life	> 1000 mating cycles
Cable size	Max. 2.5 mm ² Max. 14 AWG
Locking device	Latch lock

Product Data Sheet

Material and Environmental Parameters

Item	Specification
Boot	Polyurethane
Contacts	Cu alloy
Contact plating	Au
Insert	Polyamide
Housing	Zinc diecast (ZnAl4Cu1)
Housing plating	Cr plating
Strain relief	POM
Flame-retardant grade	UL 94 HB
Protection class	IP67
Temperature range	-30°C ~ +80°C

Standards and Certifications

Standards	IEC 61076-2-103
Solderability	Complies with IEC 68-2-20

Product Data Sheet

Product Drawing

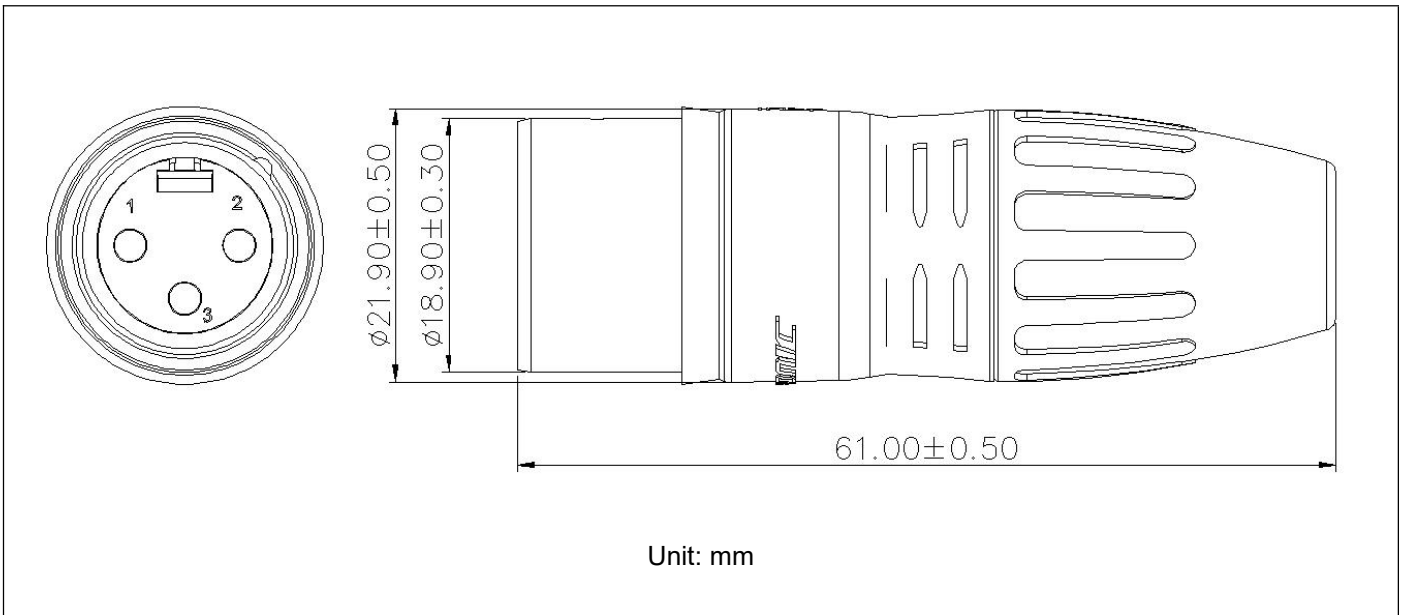

Packaging Method

1 pc per bag (include 1 pc each of inner core, housing, waterproof cable clamp, boot)
80 pcs per inner carton, 5 inner cartons per master carton (400 pcs per master carton)

Accessory

- | | |
|--|--|
| <input checked="" type="checkbox"/> No accessories | <input type="checkbox"/> Back fastener plate |
| <input type="checkbox"/> Screws and Nuts | <input type="checkbox"/> Other |

Product Data Sheet

Assembly Instructions

(1) Put the cable through the boot and waterproof cable clamp

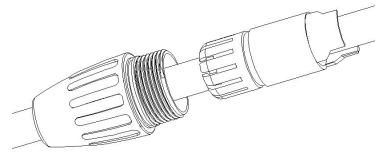

(2) Strip the cable in the size as shown

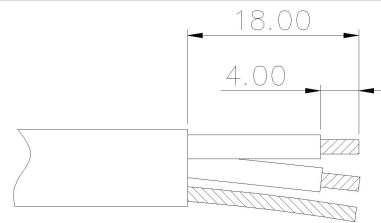

(3) Insert the conductor of the cable into the terminal of the inner core and solder

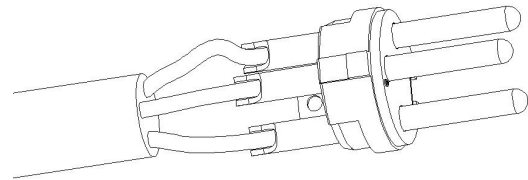

(4) Insert cable into the clamp and clip into the inner core bayonet

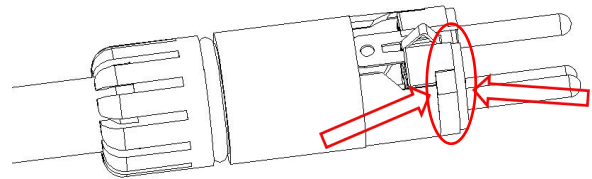

Product Data Sheet

- (5) Push the inner core component and clamp into the housing. The two protruding ribs of the inner core component should correspond to the two grooves inside the housing.

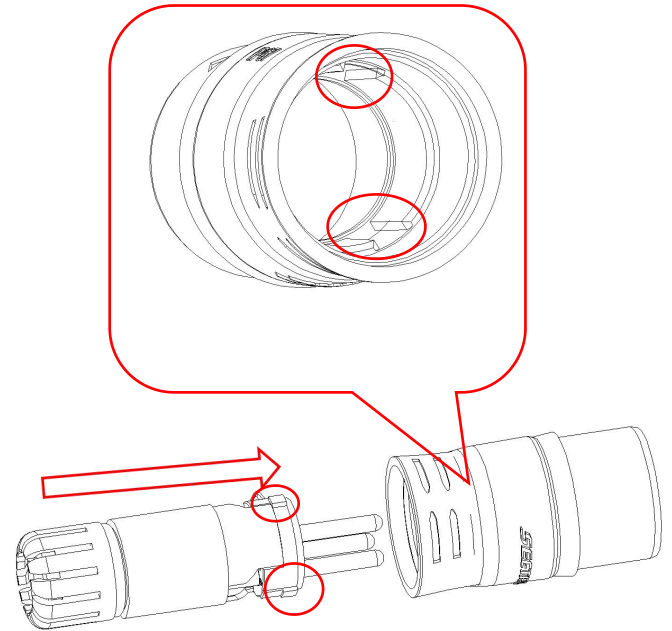

- (6) After the assembly of the clamp, inner core and housing, tighten the boot in a clockwise direction.

