

SnakeSys User Manual

Distributor:



Phone: 407-857-8770
Fax: 407-857-8771
Email: sales@techni-lux.com

REVISION HISTORY

NUMBER	DATE	DESCRIPTION	NAME
v1.6.6.9	06/03/2015		ChamSys

Contents

1	SnakeSys Products	1
1.1	SnakeSys Philosophy	1
1.2	Networking	2
2	SnakeSys B4	3
2.1	Product Diagram	4
2.2	Art-Net Output	4
2.3	Art-Net Output + DMX Input	5
2.4	ACN Output	5
2.5	ACN Output + DMX Input	6
2.6	Same Universe Output	6
2.7	ChamNet Mode	6
2.8	DMX Buffer Mode	7
2.8.1	Rotary Encoder Function, DMX Buffer Mode	7
2.9	DMX Connectors	8
2.9.1	DMX Output Connectors	8
2.9.2	DMX Input Connector	8
2.10	Powering the SnakeSys B4	8
3	SnakeSys R4	9
3.1	Product Diagram	10
3.2	Network Buttons	10
3.3	DMX Mode Buttons	10
3.4	Selection Buttons	11
3.5	Bypass Buttons	11
3.6	Address Switches	11
3.7	Power Button	12
3.8	Clear Settings Feature	12
3.9	Special Mode Feature	12
3.10	Power Over Ethernet (PoE)	12
3.11	Rear Panel Diagram	13

3.12	RDM Support	13
3.13	ChamNet Mode Information	13
3.14	Powering the SnakeSys R4	13
3.14.1	Thermal Management	14
3.14.2	Battery Care Information	14
4	SnakeSys T2	15
4.1	Product Diagram	16
4.2	DMX Connectors	16
4.3	Network Connectors	17
4.4	Menu System	17
4.4.1	Main Menu	19
4.4.2	Network Menu	21
4.4.3	Network Port Menu	22
4.4.4	Settings Menu	23
4.5	RDM Support	24
4.6	ChamNet Mode Information	24
4.7	T2 Truss Mounting	24
4.8	Powering the SnakeSys T2	25
5	SnakeSys R8	26
5.1	Product Diagram	27
5.2	DMX Connectors	27
5.3	Network Connectors	27
5.4	Menu System	27
5.4.1	Main Menu	29
5.4.2	Network Menu	31
5.4.3	Settings Menu	33
5.4.4	DMX Settings Menu	34
5.5	RDM Support	35
5.6	ChamNet Mode Information	35
5.7	Powering the SnakeSys R8	35
5.8	Security Measure Warning	35
6	Network Manager (SnakeSys)	37
6.1	Normal (non ChamNet mode)	37
6.2	ChamNet Mode (MQ Net)	37
6.3	Upgrading SnakeSys firmware	38
6.4	Older ChamSys 4 Port Ethernet interfaces	39
6.5	Output Setup	39

7 SnakeSys Firmware Release Notes (B4, R4, T2)	40
7.1 Version V213	40
7.1.1 All Products (Improve Policy For Save Of Settings)	40
7.2 Version V212	40
7.2.1 SnakeSys B4	40
7.3 Version V211	40
7.3.1 SnakeSys T2 Version 2	40
7.4 Version V210	41
7.4.1 SnakeSys R4	41
7.4.2 All Products	41
7.5 Version V209	41
7.5.1 All Products	41
7.6 Version V208	41
7.6.1 SnakeSys T2	41
7.7 Version V206	41
7.7.1 SnakeSys B4	41
7.8 Version V204	41
7.8.1 Snakesys R4	41
7.8.2 Snakesys B4	42
7.9 Version V203	42
7.9.1 Snakesys B4	42
7.10 Version V202	42
7.10.1 Snakesys R4	42
7.10.2 All Products	42
7.11 Version V201	42
7.11.1 Snakesys R4	42
7.11.2 All Products	42
7.12 Version V200	42

ChamSys Ltd



The features and functions of the MagicQ software and consoles and SnakeSys products and the ideas contained therein are the property of ChamSys Ltd. The console is intended for the control of lighting systems. No warranties are expressed or implied regarding the use of the MagicQ software of lighting consoles. No liabilities are accepted for the accuracy of the information contained within this manual.

MagicQ software and MagicQ lighting console products are supplied, designed and manufactured by ChamSys Ltd.

Products containing ChamSys Ltd software and firmware embody proprietary information and are licensed not sold and may not be duplicated in any way.

ChamSys Ltd does not guarantee the accuracy, adequacy, suitability or completeness of any information or products and is not responsible for any errors or omissions or the results obtained from use of such information or products.

ChamSys Ltd does not accept responsibility for the consequences of misuse or abuse of its equipment. The equipment is designed to meet all current regulation requirements in the UK for electrical products.

None of the equipment or software supplied by ChamSys Ltd may be used in any life-critical or potentially life-endangering situations or in situations where personal injury may result.

ChamSys Ltd reserves the right to make any changes and/or improvements or to discontinue any and all of their product's or service's without prior notice, and advises customers to obtain the latest version of relevant information to verify, before placing orders, that information being relied on is current and complete. All products are sold subject to the terms and conditions of sale supplied at the time of order acknowledgement, including those pertaining to warranty, patent infringement, and limitation of liability. Some of the available functions of products may be altered over the life of the product.

The ChamSys Ltd range of products meet EU directives where applicable, for example the EMC and LVD directives, as laid down by the European Community and ChamSys Ltd has a policy of regularly testing samples to ensure that production units continue to meet these specifications.

ChamSys Ltd will not accept goods back for repair if the serial number sticker is removed or defaced so that it is illegible. This also applies to warranty repairs. See terms and conditions of sale for full details.

All other product names are trademarks or registered trademarks of their respective owners.

No part of this publication may be reproduced or distributed, transmitted, transcribed, stored in a retrieval system, or translated into any language in any form by any means without the prior written permission of ChamSys Ltd.

Copyright 2014 by ChamSys Ltd. All rights reserved.

www.chamsys.co.uk

Chapter 1

SnakeSys Products

The SnakeSys Product range currently includes:

SnakeSys B4	A four universe Ethernet to DMX convertor. It supports four DMX512 ports that are configurable as either inputs or outputs, and one DMX port that is always assigned as an input.
SnakeSys R4	A four universe multi-purpose network distribution node comprising DMX output ports, DMX input ports and multiple network ports in a 1U rack
SnakeSys T2	A truss mountable two universe Ethernet to DMX convertor with an in-built network switch. Each universe has three separate outputs removing the need for a separate DMX buffer.
SnakeSys R8	An eight universe Ethernet to DMX convertor in a 1U rack. It supports eight DMX512 ports that are configurable as either inputs or outputs, and also features dual network ports.

1.1 SnakeSys Philosophy

SnakeSys network products enable DMX data, media data and control data to be distributed throughout the lighting rig from control consoles to fixtures. SnakeSys products can be used with any lighting console or media server - they are independent of MagicQ products.

SnakeSys products are designed and manufactured in the UK using quality electronic components, and are designed for reliability. Wherever possible, all components are mounted on a single circuit board to avoid the need for interconnecting cables. SnakeSys products are designed at a "chip" level, rather than repackaging IT products.

SnakeSys products use professional locking Neutrik Ethercon connectors for all network connections, this avoiding the limited lifetime associated with traditional RJ45 network plugs and sockets.

SnakeSys products use professional locking Neutrik Powercon connectors for power input, ensuring a reliable power input. All SnakeSys products accept voltages from 90V to 250V AC without needing any changes.

Where appropriate, SnakeSys products have in-built battery backup to protect against unexpected power loss.

SnakeSys products support Power over Ethernet - the SnakeSys B4 and T2 can both be powered directly from the R4 rack nodes and switches using Power over Ethernet rather than from the mains - this reduces the number of cables in the system.

SnakeSys products support firmware updates over the network, enabling the products to be easily upgraded to support new features.

1.2 Networking

SnakeSys products support Art-Net I, Art-Net II and Art-Net III, along with ACN Streaming DMX network protocols. The DMX512 ports are fully configurable with DMX packet length, framing rate, and timings.

All SnakeSys products ship with a 2.X.X.X IP address and 255.0.0.0 Subnet Mask as standard. It is important that any consoles, PCs or Macs that will be communicating with SnakeSys products are set within this IP address range. SnakeSys products have inbuilt Ethernet switches with auto MDI/MDIX detection, so when connecting directly between a PC/Console and SnakeSys products a cross over Ethernet cable is not required.

If you change the IP address of the SnakeSys product it will not show up again in Net Manager until you have reconfigured the network on your system to be within the same range as the Interface.

All SnakeSys products unlock MagicQ PC/Mac Software from Demo mode when connected over network regardless of the mode set up on the SnakeSys product, allowing access to the restricted features of MagicQ.

SnakeSys products with USB ports are for initial factory programming and should not be connected under normal use.

Chapter 2

SnakeSys B4

The SnakeSys B4 is a four universe DMX to Ethernet convertor. It supports four DMX512 ports that are configurable as either inputs or outputs and one DMX port that is always assigned as an input. The SnakeSys B4 is designed as a multi purpose box to be used in places where a small portable Ethernet to DMX conversion solution is required.

- Universal Ethernet to DMX Interface
- Four DMX512 Ports (configurable as input or output)
- One dedicated DMX512 input port
- Art-Net and ACN Streaming DMX support
- Can be used with any Art-Net or ACN compliant console
- Universe selectable by rotary switches
- ChamNet remote configuration
- Stand-alone DMX buffer mode
- Can be powered by Power over Ethernet

Multiple SnakeSys B4s can be used on a single network, either configured directly from the unit or by using ChamNet control from a MagicQ console. Multiple SnakeSys B4s can be synchronised together to ensure that the DMX output from the console is consistent and does not involve "tearing" either within universes or across multiple universes.

2.1 Product Diagram

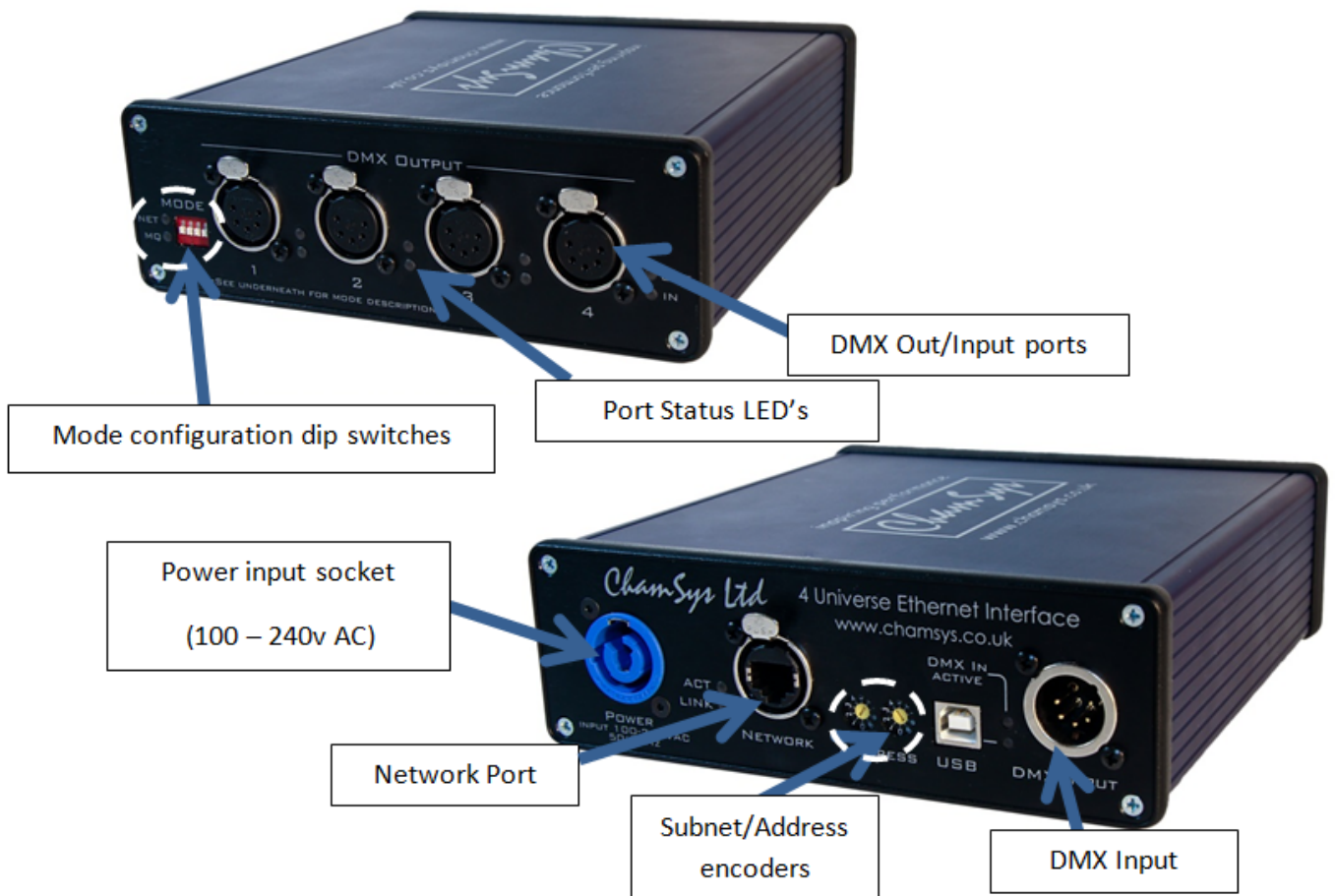

For simple Art-Net or ACN to DMX output conversion on the SnakeSys B4 the DIP switches/rotary encoders can be used to quickly configure the device for this mode.

2.2 Art-Net Output

On the DMX output end of the B4, the DIP switches are used to configure the device mode. For Art-Net to DMX output mode DIP Switch 4 (switch nearest Socket 1) should be up and all other DIP switches should be in the down position.



The rotary encoders on the reverse side of the unit are used to configure the Art-net Subnet and Universe. In this mode universes following sequentially, so for example when set to 0-0 the 4 DMX output ports would map to Subnet 0, Universes 0, 1, 2, 3 respectively. The LEDs next to the DMX output sockets will light in Blue when the DMX port is active and the unit is outputting DMX.



2.3 Art-Net Output + DMX Input

This mode is exactly the same as Art-Net Output except that the DMX Input connector on the rear of the unit is enabled, DIP Switch 2 is used to enable the rear DMX Input.



The Input Art-Net Universe follows after the 4 Output Universes, so for example when the rotary encoders are set to 0-0 the 4 DMX Output Ports would map to Subnet 0, Universes 0, 1, 2, 3 and the DMX Input would generate Art-Net Universe 4.

The DMX Input LED will illuminate when the B4 is receiving DMX.

2.4 ACN Output

On the DMX output end of the B4, the DIP switches are used to configure the device mode. For ACN to DMX output mode DIP Switch 3 should be up and all other DIP switches should be in the down position.



The rotary encoders on the reverse side of the unit are used to configure the ACN Universes. With the left hand encoder setting the ten value and the right encoder setting the unit value.



In this mode universes following sequentially, so for example when set to 0-1 the 4 DMX output ports would map to ACN Universes 1, 2, 3, 4 respectively. The LEDs next to the DMX output sockets will light in Blue when the DMX port is active and the unit is outputting DMX.

2.5 ACN Output + DMX Input

This mode is exactly the same as ACN Output except that the DMX Input connector on the rear of the unit is enabled, DIP switch 2 is used to enable the rear DMX Input.



The Input ACN Universe follows after the 4 Output Universes, so for example when the rotary encoders are set to 0-1 the 4 DMX Output Ports would map to ACN Universes 1, 2, 3, 4 respectively, and the ACN Input Universe will be ACN Universe 5.

The DMX Input LED will illuminate when the B4 is receiving DMX.

2.6 Same Universe Output

When the B4 is operating in either Art-Net or ACN mode the DIP Switch Position 1 can be used to optionally enable all 4 DMX Outputs to output the same universe, i.e. the first universe selected by the Rotary Encoders. The B4 will output the same universe when DIP Switch Position 1 is in the UP position.

In the case where the DMX Input feature is also enabled, the DMX Input will generate DMX Output Universe + 1.

2.7 ChamNet Mode

Running the B4 in ChamNet Mode allows the device to be custom configured. In this mode MagicQ can be used to configure each port individually, set DMX timing and refresh rates along with setting the units IP Address and Subnet Mask. The unit can also be firmware upgraded using MagicQ when in ChamNet mode. On the DMX output end of the B4, the dip switches are used to configure the device mode.

For ChamNet Mode all DIP switches should be in the down position.



When the unit is in ChamNet mode the rotary encoders are used to set the units MagicQ box id. This is only useful if you have more than one SnakeSys product attached to the network, as each SnakeSys product should have its own unique ChamNet address. If you only have one SnakeSys device attached you can safely leave the rotary encoders both set to zero.



The Unit can be accessed within MagicQ under Net Manager, found under Setup > View DMX I/O > Net Manager.

Note

If the unit product version is **B4 MK2 or later** the unit will remember the settings that you make in MagicQ Net Manager. Please allow at least 40 seconds for the unit to store the information into flash memory before removing the power. If the unit is left in MagicQ ChamNet mode it will boot up with the settings that you made previously in Net Manager (MagicQ will not be required to be connected to keep the port settings). This is a useful work around if you need to pre-configure port settings outside the options that are available through the normal DIP switch settings for use without MagicQ. This save to flash feature is not available on **B4 MK1**.

2.8 DMX Buffer Mode

The SnakeSys B4 can also be used as a simple DMX buffer, giving 4 DMX outputs from a single DMX input.

For DMX buffer Mode DIP switch 1 should be in the up position with all other DIP switches down.



2.8.1 Rotary Encoder Function, DMX Buffer Mode

The rotary encoders when the unit is operating in DMX buffer mode allow some adjustments to the DMX output protocol, including DMX packet rate, DMX packet length, DMX break length and overall DMX frame timing.

Note

These are advanced options, if you do not fully understand what the DMX packet timings actually adjust with regards to the DMX output, or you would just like the default setting you should set both encoders to 0 when using DMX buffer mode.

**Note**

A version of the tables below is also written on the base of the B4 unit for quick reference in the field.

Table 2.1: Packet Rate and Length [Left Encoder]:

Num Channels	Rate 40Hz	Rate 33Hz	Rate 25Hz
512	0	1	2
256	3	4	5
128	6	7	8
64			9

Some examples using the above table:

- Setting position 2 on the **Left Encoder** will give 512 DMX output channels at a 25Hz update rate.
- Setting position 6 on the **Left Encoder** will give 128 DMX output channels at a 40Hz update rate.

Table 2.2: Frame Timing [Right Encoder]:

Break (uS)	Frame 48uS	Frame 56us	Frame 64uS
92	0	1	2
176	3	4	5
256	6	7	8
384	9		

Some examples using the above table:

- Setting position 3 on the Right Encoder will give DMX break of 176uS and the frame data bytes will take 48uS
- Setting position 8 on the Right Encoder will give DMX break of 256uS and the frame data bytes will take 64uS

2.9 DMX Connectors

2.9.1 DMX Output Connectors

The four DMX Output connectors are bi-directional and can be configured either as DMX Output or DMX Input however they can only be set as Inputs when the unit is used in ChamNet mode through the Net Manager. When using any DMX Output channel as a DMX Input a male to male 5 pin gender adaptor or equivalent cable may be required.

2.9.2 DMX Input Connector

The DMX Input connector on the rear of the unit can only be used as an Input. The DMX Input connector when enabled can be used in Art-Net, ACN and ChamNet mode.

2.10 Powering the SnakeSys B4

The B4 can be powered either by the mains Powercon Input socket or via PoE (Power over Ethernet) from a compatible device such as the SnakeSys R4, when running via PoE the B4 accepts between 37-57V and takes 6.5-12.9W.

The mains power supply is universal wide input range type and has the following specification: **85 to 264VAC @ 47 to 63 Hz or 120 to 370VDC**

The SnakeSys B4 does not have an internal battery.

Chapter 3

SnakeSys R4

The SnakeSys R4 is a multi-purpose network distribution node, comprising DMX output ports, DMX input ports and multiple network ports in a 1U rack.

The SnakeSys R4 is designed to be used on stage for Ethernet to DMX conversion, at front of house for DMX to Ethernet conversion, and in any other location that requires conversion between DMX and Ethernet or Ethernet switching.

Using one SnakeSys R4 at front of house and one SnakeSys R4 at stage interconnected by a single CAT 5 network cable, the system provides four DMX lines and three independent network lines all over one cable.

The SnakeSys R4 is a 1U rack featuring:

- Powercon input
 - Battery backup
 - Three Ethercon network connections on front (all can supply Power over Ethernet)
 - Two Ethercon network connections on rear
 - Four 5-pin DMX output sockets on the front
 - Four 5-pin DMX input sockets on the rear
 - Full break detect on all four DMX inputs
 - Two remote contact inputs
 - Relays to automatically connect inputs to outputs in the event of a power failure
-

3.1 Product Diagram

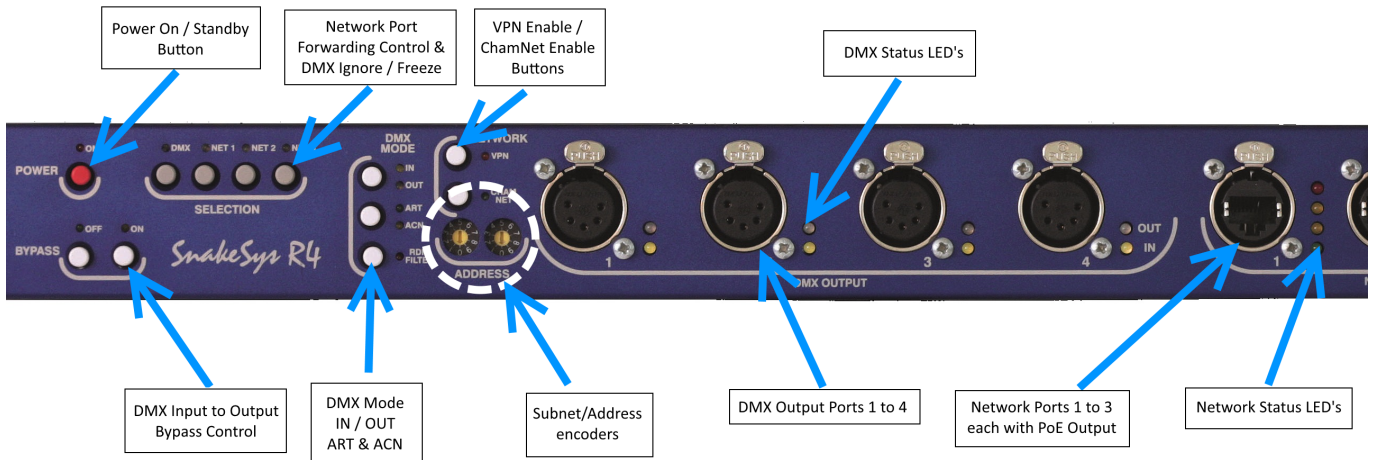

3.2 Network Buttons

- **CHAMNET**

Enables ChamNet mode for use with MagicQ console, or disables ChamNet mode where local control mode will be used instead.

- **VPN**

Enables **VPN** (VLAN) mode, which is used to connect two R4 units together and create a virtual private network. Connect a network cable between **NET4** on both units and enable the VLAN with the **VPN** button and the LED will illuminate. **NET1**, **NET2** and **NET3** and **NET5** will each become a separate **VPN** on both units.

Table 3.1: VPN (VLAN) Connectivity:

Unit #1 NET Port	Unit #2 NET Port	Connection
NET1	NET1	Virtual LAN (Port to Port)
NET2	NET2	Virtual LAN (Port to Port)
NET3	NET3	Virtual LAN (Port to Port)
NET5	NET5	Virtual LAN (Port to Port)

Note

Each of the network connectors will behave as separate networks.

When in **VPN** Mode, **NET5** is still linked to the processor on each of the R4 units. Using **NET5** on either one of the two units will allow both of the units to be accessed.

3.3 DMX Mode Buttons

- **IN / OUT**

When the unit is not in ChamNet mode this button can be used to configure the unit as DMX input (on the rear connectors) or DMX output (on the front connectors).

- **ART / ACN**

When the unit is not in ChamNet mode this button can be used to configure the unit as sending or receiving Art-Net or streaming ACN.

- **RDM FILTER**

At present this button has no function - this will be included in a future firmware update.

3.4 Selection Buttons

- **DMX**

When the unit is configured as DMX OUT then the DMX button causes the unit to ignore incoming DMX network packets and freeze the DMX output. When the unit is configured as DMX input the DMX button will prevent DMX network packets from being placed onto the network.

- **NET1, NET2, NET3**

These three network buttons disable the packet forwarding on each of the front three network sockets **NETWORK 1**, **NETWORK 2**, **NETWORK 3** respectively. This disables the socket but keeps the link active, and allows for selection of console via the front-panel of the unit. These buttons still work as expected if the unit is operating in **VPN** mode. These buttons do not affect Power over Ethernet (PoE) output.

3.5 Bypass Buttons

- **ON**

When the bypass is enabled the unit links the 4 DMX inputs on the back to the 4 DMX outputs on the front, so **DMX1** links to **DMX1**, **DMX2** links to **DMX2** etc. This bypasses the entire unit and can be used to allow the DMX inputs to take control of the show. When the unit is fully powered off, the bypass relays will automatically activate.

- **OFF**

This disables the bypass when the unit is powered up and puts the unit into normal operation mode.

3.6 Address Switches

The leftmost address switch controls tens the rightmost address switch controls units.

Address Switches (ChamNet mode) When the unit is placed into ChamNet mode the address switches control the unique identifier for the unit, this will appear in MagicQ in the NET MANAGER when the unit is detected.

Address Switches (Art-Net mode) When the unit is placed into Art-Net mode the address switches control the Art-Net universe.

Address Switches (sACN mode) When the unit is placed into sACN mode the address switches control the ACN universe.

Please note that the first available ACN universe is 1 so switch setting 0 - 0 should not be used in ACN mode.

3.7 Power Button

- **POWER**

The **POWER** button is used to shut down (when on battery power) or place the unit in standby (when on mains power). Since the unit has an internal UPS when the unit is in standby it will still charge the battery. It is normal that the fan continues to run in standby mode.

When the power LED flashes it means that the unit has detected the loss of mains power and it is running on battery back-up. Depending on the load conditions regarding Power over Ethernet on the front three network ports, the unit should run for approximately 30 to 40 minutes on battery. When the unit is running off battery back-up it monitors the network link status and DMX inputs and will auto shut off if there is no activity after a predetermined period of time. The feature prevents the battery from being depleted should the power be removed when the show shuts down.

3.8 Clear Settings Feature

The R4 has a feature to enable all settings to be reset to factory default. The procedure to clear the settings is to hold down buttons **NET1**, **NET2** and **NET3** simultaneously and also while keeping the net buttons held down then press and hold the ChamNet button. The R4 will then reboot and factory default settings will be restored.

3.9 Special Mode Feature

Note

This is a newer feature, please ensure firmware version \geq v210 is installed.

Holding down the **DMX** button for 5 seconds will cause R4 to enter special mode selection. One or more of the **NET** buttons can then be used to enable or disable extended DMX feature. During special mode selection the **DMX** button LED will flash.

Table 3.2: Special Mode Table

Special Mode	LED On	LED Off
NET1	DMX Input uses software based break detect	DMX Input uses hardware based break detect
NET2	Future Expansion	Future Expansion
NET3	Future Expansion	Future Expansion

Once the required special mode has been selected pressing the **DMX** button again will save the feature to flash and the selected feature will become immediately active. The unit will then return to regular frontpanel function.

3.10 Power Over Ethernet (PoE)

The SnakeSys R4 contains a fully isolated and standards compliant Power over Ethernet system. PoE output source is available on the front three network sockets by plugging in a PoE compliant network device.

3.11 Rear Panel Diagram

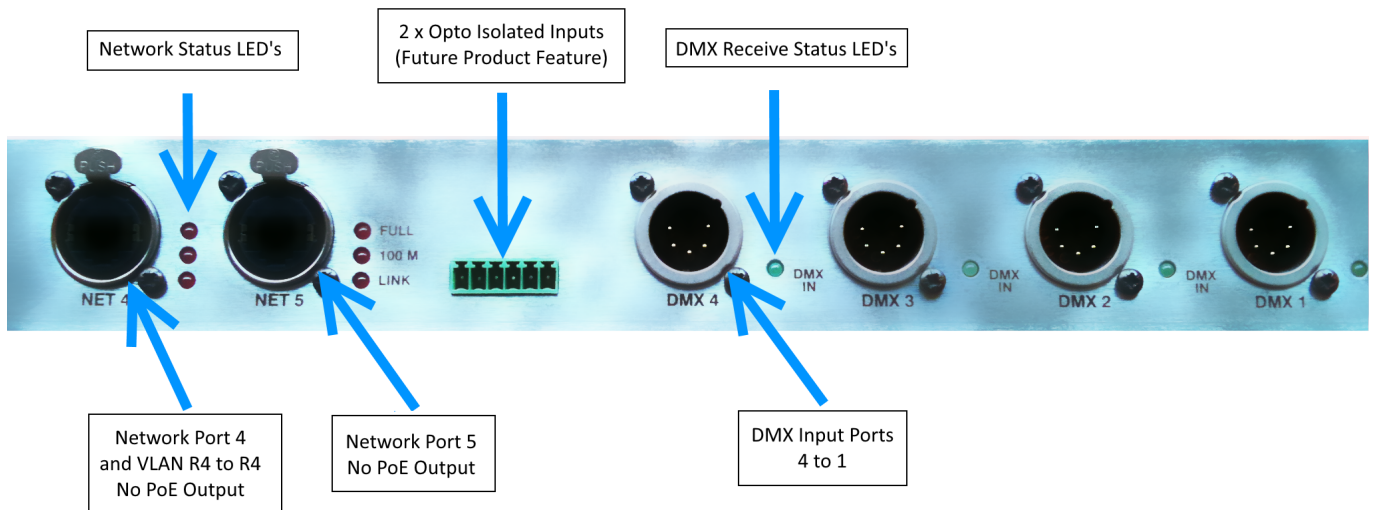

The two **NET** ports on the back of the device do not have PoE (Power over Ethernet) functionality. Both ports can be of general use, and **NET4** can also be used as the **VPN** link between two R4 units.

3.12 RDM Support

The R4 hardware supports full RDM functionality, however RDM is not currently supported in R4 firmware.

3.13 ChamNet Mode Information

In ChamNet Mode, the SnakeSys R4 is configured and controlled from the Net Manager within MagicQ.

Note

The R4 unit will remember the settings that you make in MagicQ Net Manager. If the unit is left in MagicQ ChamNet mode it will boot up with the settings that you made previously in Net Manager. (MagicQ will not be required to be connected via network to retain the settings).

3.14 Powering the SnakeSys R4

SnakeSys R4 is powered using the supplied Powercon cable.

The power supply is universal wide range input type and has the following specification: **85 to 264VAC @ 47 to 63Hz**



Caution

During usage please ensure that the unit has adequate ventilation and that the cooling grilles on the unit are not obstructed.

3.14.1 Thermal Management

The SnakeSys R4 contains its own thermal management system. The fan is automatically controlled for regulation of the internal temperature of the unit.

3.14.2 Battery Care Information

The inbuilt UPS feature of the SnakeSys R4 is powered by a Battery. If planning to place the unit into long term storage it is recommended to first re-charge the battery by leaving the unit on mains power for at least 2 hours. Storing a unit with a low battery level for a number of months without periodic use can dramatically reduce the operational life of the battery.

Chapter 4

SnakeSys T2

The SnakeSys T2 is a rugged truss mountable two universe Ethernet to DMX convertor with an in-built network switch supporting three separate DMX output sockets per universe.

- Two universes
 - Three 5-pin DMX output sockets per universe
 - Four network ports
 - Can be powered by Power over Ethernet
 - Can be used with any Art-Net or ACN compliant console
 - LCD display and buttons for configuration
 - RDM capability (subject to firmware development)
 - Serial port connector - e.g for connecting projectors
 - Hook clamp fixable in three different orientations
 - Omega clamp fixable in four different orientations
 - Can be configured without power (inbuilt battery)
-

4.1 Product Diagram

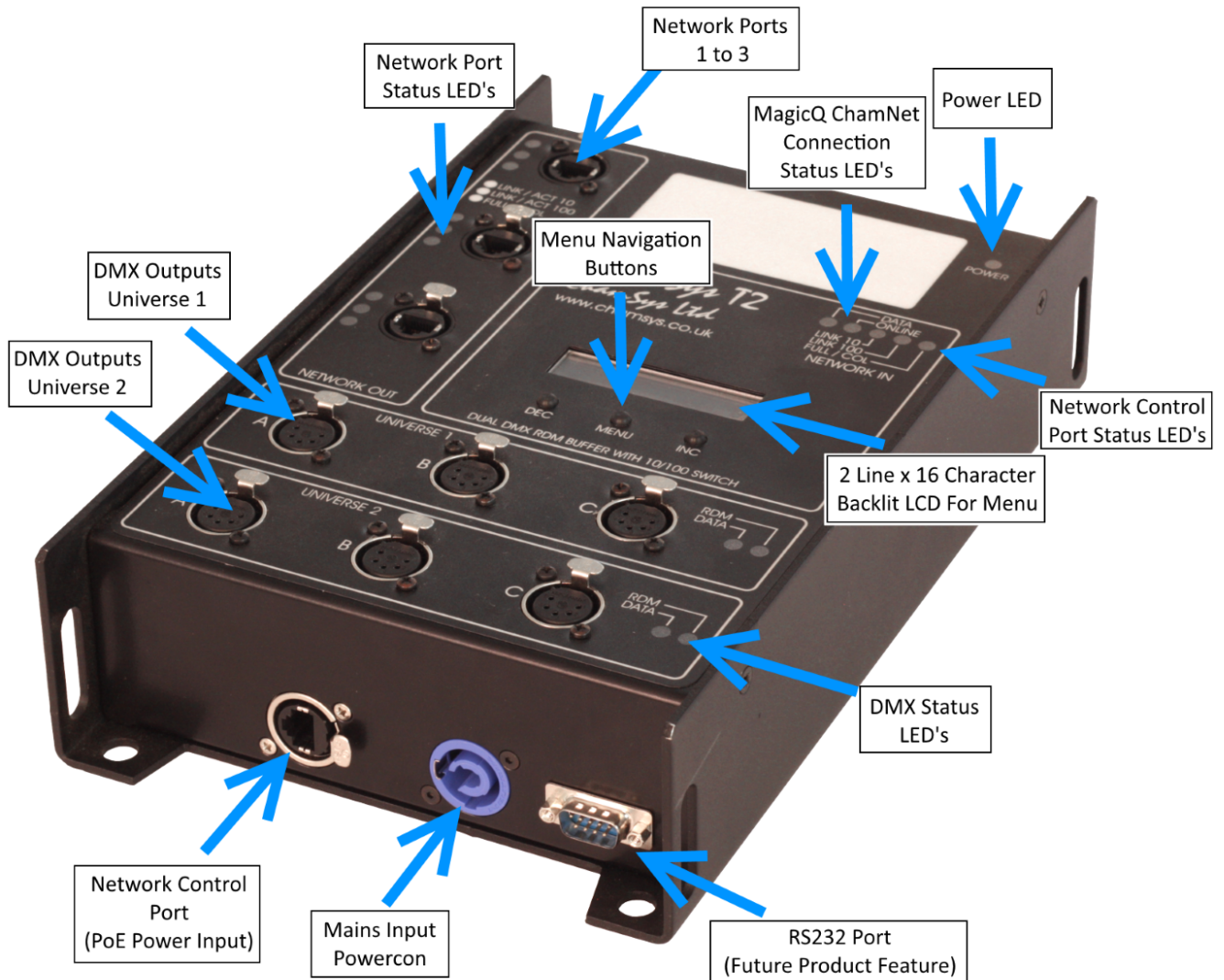

Note

Image shown in diagram is T2 product version MK1

For Simple Art-net or ACN to DMX output conversion the SnakeSys T2 inbuilt menu system can be used to quickly configure the device for the required mode.

The T2 can be powered either by the Powercon Input socket or via PoE (Power over Ethernet) from a compatible device such as the SnakeSys R4, when running via PoE the B4 accepts between 37-57V and 6.5-12.9W.

The T2 has an internal battery for configuring the unit without the need for connecting to a power source. The battery is used for addressing and setup of the unit only.

If running it battery mode and not connected to a power source press the menu button once to power on.

4.2 DMX Connectors

The SnakeSys T2 has a total of six DMX Output connectors. The DMX Output connectors are arranged in two rows of three. When operating in Art-Net or ACN mode the top row of DMX connectors output the first universe that the unit is addressed

to, and the second row of DMX connectors output the current universe address + 1. All DMX Outputs are Opto-Isolated, even though each group of three output the same universe.

Note

The SnakeSys T2 MK2 includes an additional DMX Input connector, which is used to provide a DMX Buffer feature and additional DMX Input option for Art-Net and ACN modes.

Note

The additional DMX Input connector on the T2 MK2 is not currently supported in MagicQ ChamNet mode.

4.3 Network Connectors

The SnakeSys T2 has a total of 4 Ethernet Network connectors. The function of these connectors is identical, and they are connected to the same network switch, and they can be used for communication with the T2 device and other devices connected to any of the T2 network ports. The PoE network connector located next to the Powercon connector on the base of the unit also has additional power distribution circuitry for powering the T2 via PoE (Power over Ethernet).

Due to the circuit difference with the PoE input connector in some circumstances when the T2 is connected with an incorrectly wired Ethernet cable, the network side of the PoE connector may appear not to function when compared to plugging the incorrectly wired cable into the other network connectors. This is completely normal.

The three network connectors on the front of the unit can have packet forwarding enabled or disabled via the Network Port Menu. In the menu they are referred to as ports A, B and C from top to bottom respectively. When default settings are applied, all the connectors have packet forwarding enabled.

4.4 Menu System

The SnakeSys T2 is operated using an in-built menu system.

The **MENU** button is dual purpose and serves as an enter button as well. In all cases the **INC** and **DEC** buttons are used to either increase or decrease values or selections respectively and generally combined with the enter key provide basic menu navigation.

Pressing the **MENU** button from the Top Screen will cause the T2 unit to enter the main menu. If the unit is left navigating one of the menu's and no buttons are pressed for some time the unit will automatically return to the Top Screen.

When in ChamNet mode any changes applied to each T2 universe will be automatically updated on the Top Screen.

If backlight timeout is not set to infinite then the unit will automatically turn off the backlight after the user set time in the backlight menu if no buttons are pressed.

The top level screen provides immediate information regarding both universes, which includes protocol and address:

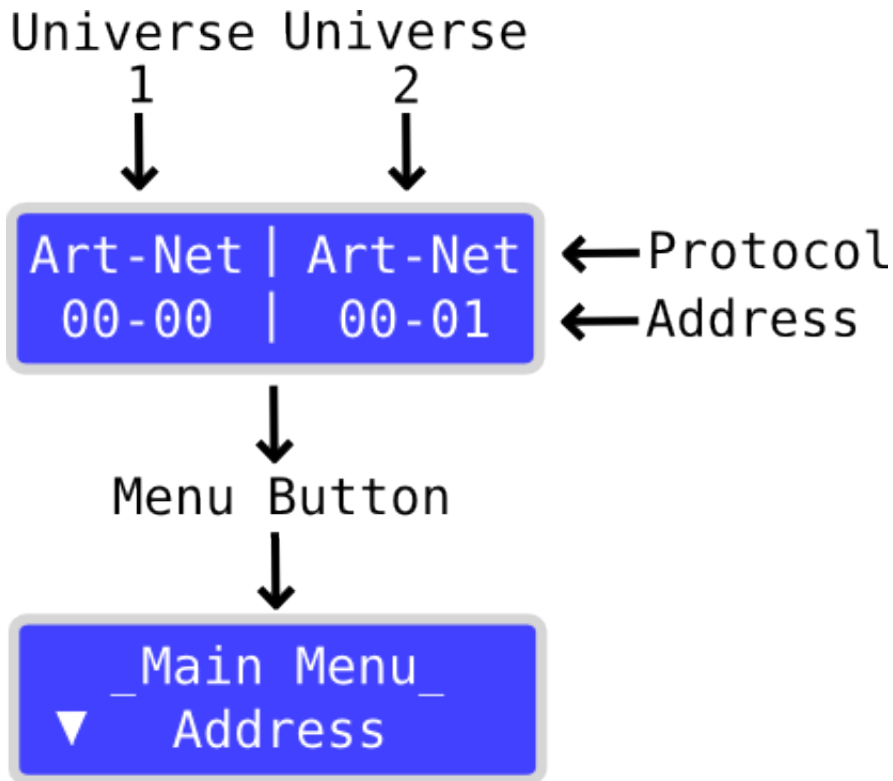

4.4.1 Main Menu

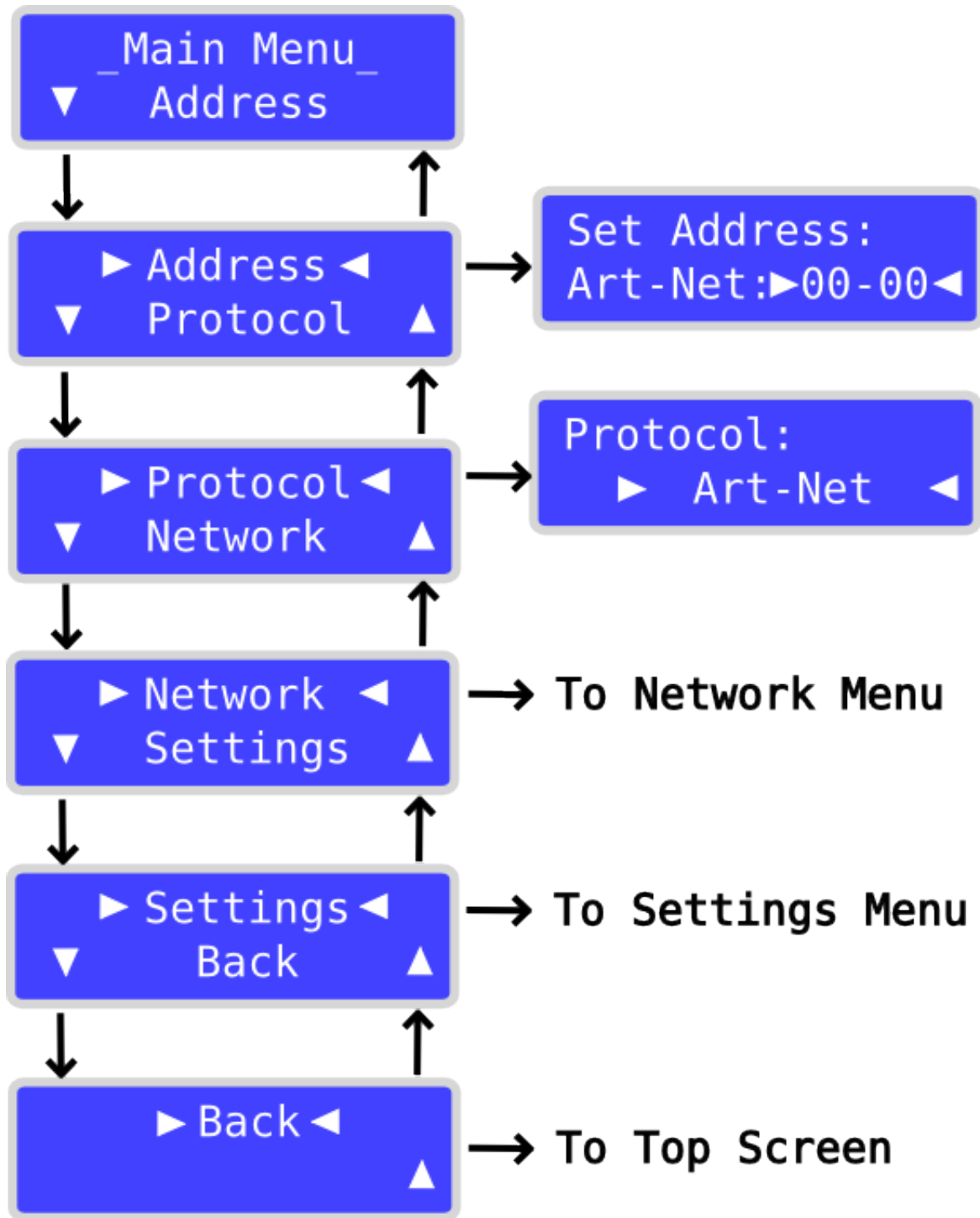

- Address

Used to set the T2 address / universe, which can be either:

Menu Item	Function
Box Id	ChamNet Mode
Art-Net universe	Art-Net Mode
sACN universe	sACN Mode

- Protocol

Used to set the network protocol used by the T2, there are now two versions of the unit the MK2 version T2 has an additional DMX input, both units use the same firmware but the MK2 has some additional features present in the Protocol menu. The MK1 unit will still be supported although we are no longer shipping the MK1 and it has been replaced by the more advanced MK2. The available options are listed below along with the product version:

Menu Item	Function	Product Version
Not Enabled	No DMX output	T2 MK1 and MK2
MQ ChamNet	Controlled by MagicQ	T2 MK1 and MK2
Art-Net	Art-Net Mode	T2 MK1 and MK2
Art-Net + In	Art-Net Mode with DMX Input enabled	T2 MK2 Only
ACN	sACN Mode	T2 MK1 and MK2
ACN + In	sACN Mode with DMX Input enabled	T2 MK2 Only
DMX Buffer	Unit operates as a simple DMX Buffer	T2 MK2 Only

4.4.2 Network Menu

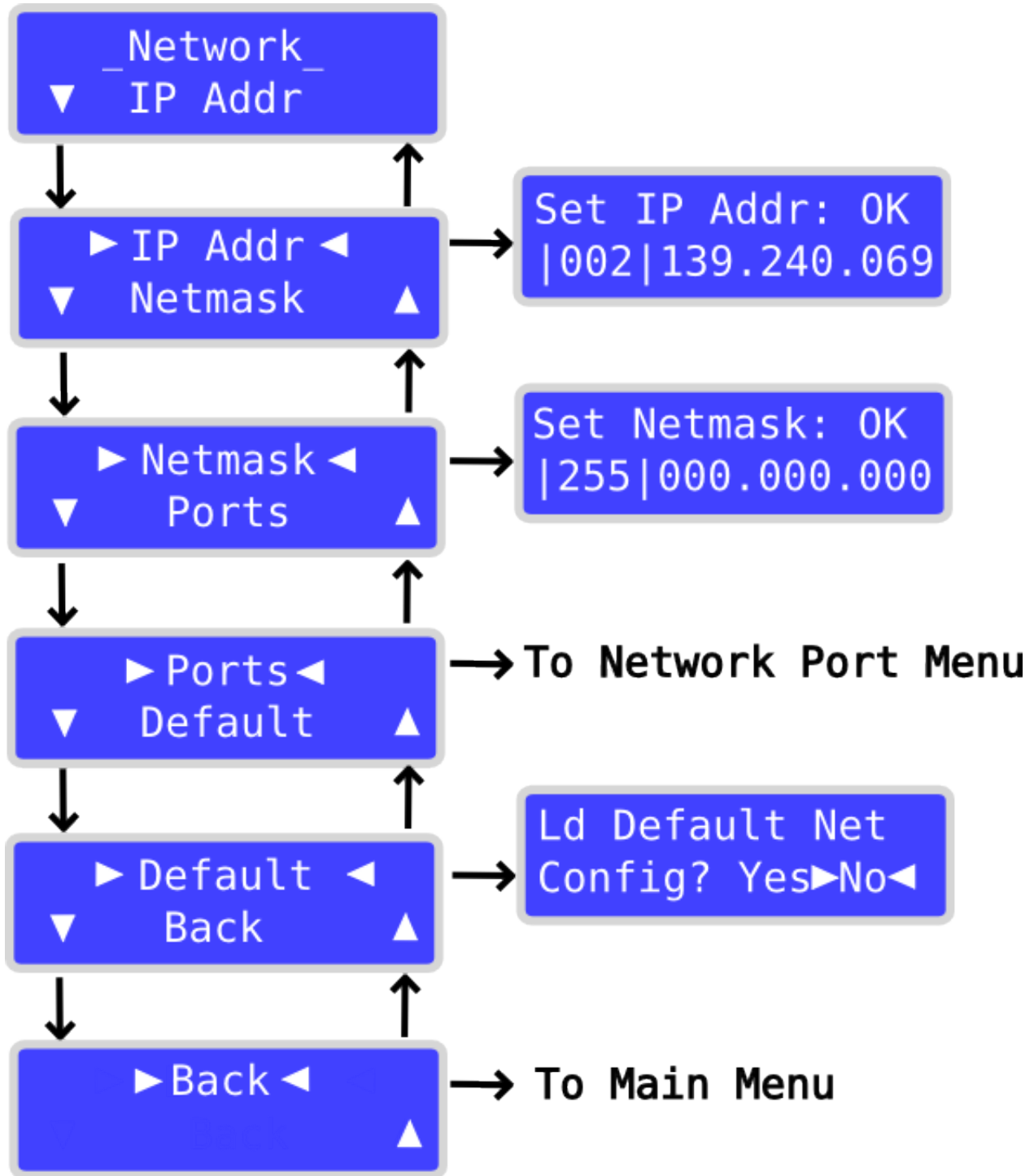

Menu Item	Function
IP Addr	Used to set the T2 network IP address used by the T2 processor. The IP address is automatically chosen when the T2 units default settings are applied, however sometimes it is necessary to change the address. This is an advanced option.

Menu Item	Function
Netmask	Used to set the T2 network sub-net mask which is applied to all network data that the T2 processor receives. This is an advanced option, The default subnet mask is normally 255.0.0.0
Default	Used to restore default networking settings to the T2. Everything which can be adjusted in the Network menu or any of its sub-menus is restored to factory default settings.

4.4.3 Network Port Menu

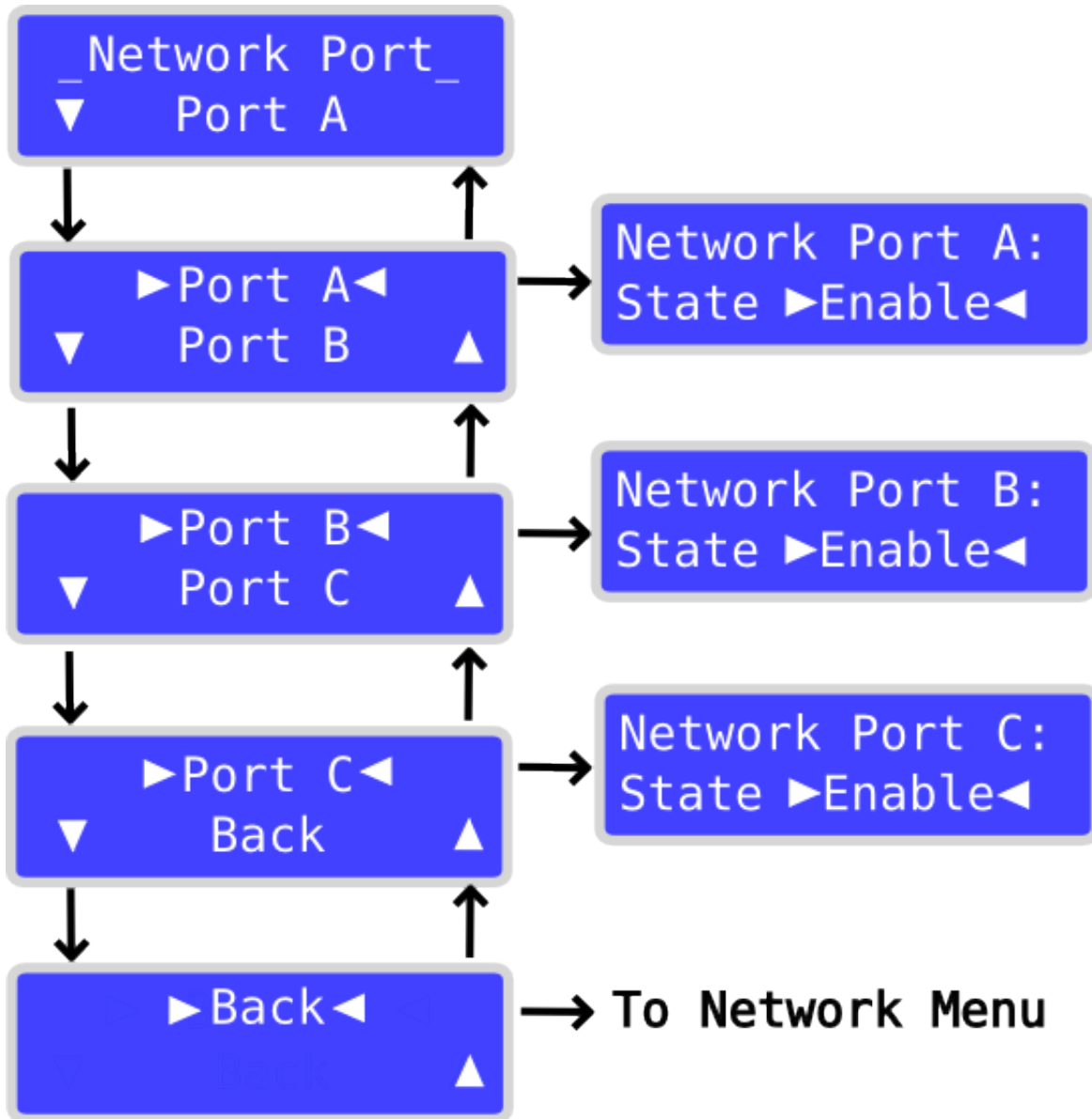

Menu Item	Function
Port A, Port B, Port C	Used to enable or disable network packet forwarding for the respective network port on the front of the T2 unit. (Port A is the top-most port on the T2). The default setting is enabled.

4.4.4 Settings Menu

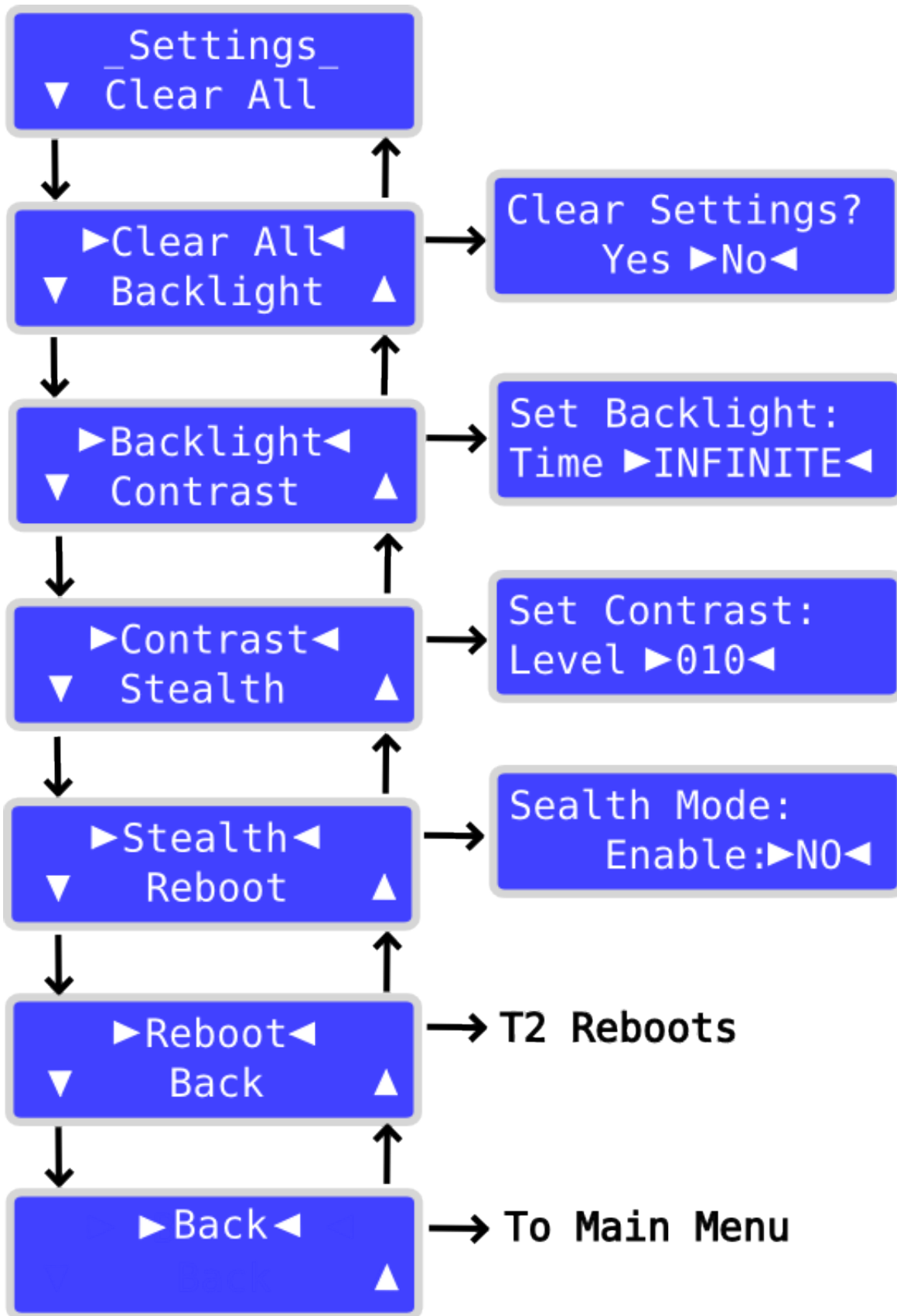

Menu Item	Function
Clear All	Used to clear all T2 settings, and restore the entire unit to factory default settings. The T2 will automatically reboot after default settings are restored.
Backlight	Used to set the backlight timeout for the LCD display. This is for how long the backlight stays on after a button has been pressed.
Contrast	Used to set the LCD display contrast.
Stealth	Used to enable Stealth Mode on the T2. When the unit is in Stealth Mode the network and DMX LED's are disabled to make the unit appear darker. You can also make the unit darker if you enable the backlight timeout feature. If you require the unit to be completely dark then that can be achieved by using the Led Status option on MagicQ and selecting Off. The LED status option will turn off all light from the unit including the display, however the feature currently is only available in ChamNet mode.
Reboot	Used to completely reboot the T2 unit.

4.5 RDM Support

The T2 hardware supports full RDM functionality, however RDM support does not currently exist in the current version of the T2 firmware. RDM support will be implemented in a future firmware release.

4.6 ChamNet Mode Information

In ChamNet Mode the SnakeSys T2 is configured and controlled from the Net Manager within MagicQ.

- DATA LED

The red DATA LED on the SnakeSys T2 indicates that valid ChamNet network data is being received by the unit.

- ONLINE LED

The green ONLINE LED on the SnakeSys T2 indicates that the unit has recently sent T2 device information to MagicQ and should have consequently appeared as online in the MagicQ Net Manager.

Note

The T2 unit will remember the settings that you make in MagicQ Net Manager. Please allow at least 40 seconds for the unit to store the information into flash memory before removing the power. If the unit is left in MagicQ ChamNet mode it will boot up with the settings that you made previously in Net Manager. (MagicQ will not be required to be connected via network to retain the settings).

4.7 T2 Truss Mounting



Caution

If the T2 unit is installed into Truss using clamps then additional care should always be taken to ensure that the unit is installed with an adequate safety chain firmly attached through the T2 rear chassis. Care should also be taken to ensure that the units clamp is securely fastened to the Truss, and only T2 clamp mounts supplied by ChamSys Ltd are recommended.

4.8 Powering the SnakeSys T2

There are three methods in which the SnakeSys T2 can be powered:

Mains supply via Powercon connector on the base of the unit	The power supply is universal wide range input type and has the following specification: 85 to 264VAC @ 47 to 63 Hz or 120 to 370VDC
PoE (Power over Ethernet)	Using the network connector located next to the Powercon connector on the base of the unit.
Battery	Pressing the "Menu" button when no power is supplied to the unit will cause the T2 to enter "Battery Mode". When in battery mode the address and mode of operation can be set via the menu. This is a useful feature as the unit can be addressed and configured without the presence of any stage power. When in battery mode the unit will automatically turn off after 1 minute of inactivity. DMX and Network operations are not available in battery mode.

Note

It is possible to connect up both Mains and PoE supplies at the same time which provides some fail safe redundancy should one of the supplies fail for some reason.

Chapter 5

SnakeSys R8

The SnakeSys R8 is an eight universe Ethernet to DMX convertor in a 1U rack. It support eight DMX512 ports that are fully configurable as either inputs or outputs. It also features dual Neutrik Ethercon network ports.

The SnakeSys R8 is designed to be used on shows where large numbers of universes are in use and there is a need to convert to and from DMX. It provides the ability to easily switch between different Ethernet or DMX sources.

- Universal Ethernet to DMX interface
 - Eight DMX512 ports, configurable as outputs or inputs
 - Dual Ethernet ports
 - Art-Net and ACN support
 - Can be used with any Art-Net or ACN compliant console
 - LCD display with multi-switch selection
 - ChamNet remote configuration
 - Stand alone DMX buffer mode
-

5.1 Product Diagram

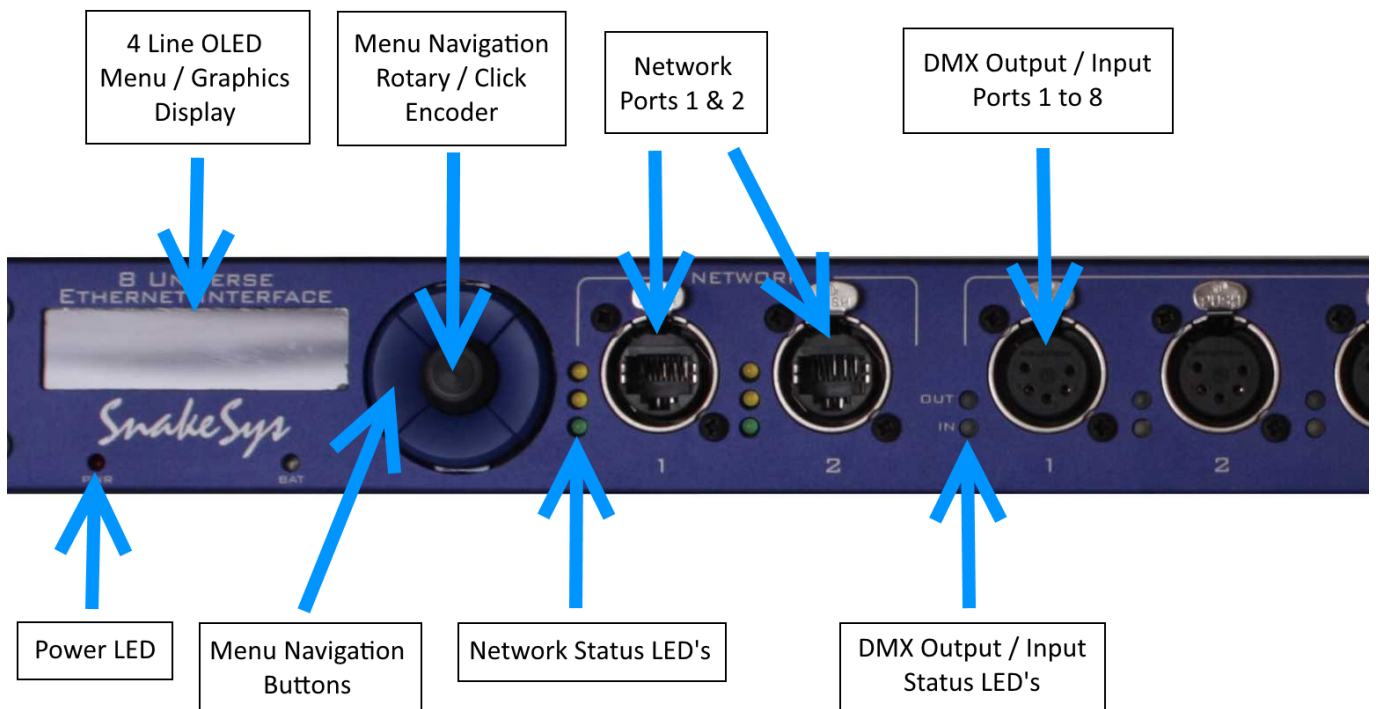

5.2 DMX Connectors

The DMX connectors are bi-directional and can be configured either as DMX Output or DMX Input. When using any channel as DMX Input a male to male 5 pin gender adaptor or equivalent cable may be required.

5.3 Network Connectors

The SnakeSys R8 has a total of two Ethernet Network connectors. The function of the network connectors are identical, and they are connected to the same network switch, they can be used for communication with the R8 device and additionally other devices connected to the other R8 network port.

Note

Care should be taken to avoid any network loop caused by incorrect network connection in your configuration, one symptom of a network loop is that the R8 will be overloaded with excessive network traffic and as a result the main menu will seem unresponsive. If you notice the symptom, please re-check your networking connections and correct accordingly.

5.4 Menu System

The SnakeSys R8 is operated using an in-built menu system.

The interface incorporates an encoder, for changing menu item values, which also acts as a push button with enter functionality. There are also **UP / DOWN / LEFT** and **RIGHT** buttons which can also be used for navigation and change of menu items.

The top level screen provides some immediate information regarding each of the 8 ports, and also indicates the units base address, protocol, and firmware version.

Pressing the any button or rotating the encoder during display of the Top Screen will cause the R8 unit to enter the main menu. If the unit is left navigating one of the menu's and no button or encoder movement is detected for some time the unit will automatically return to the Top Screen. When in the R8 is in ChamNet mode the protocol or direction changes applied to each R8 port will be automatically updated on the Top Screen.

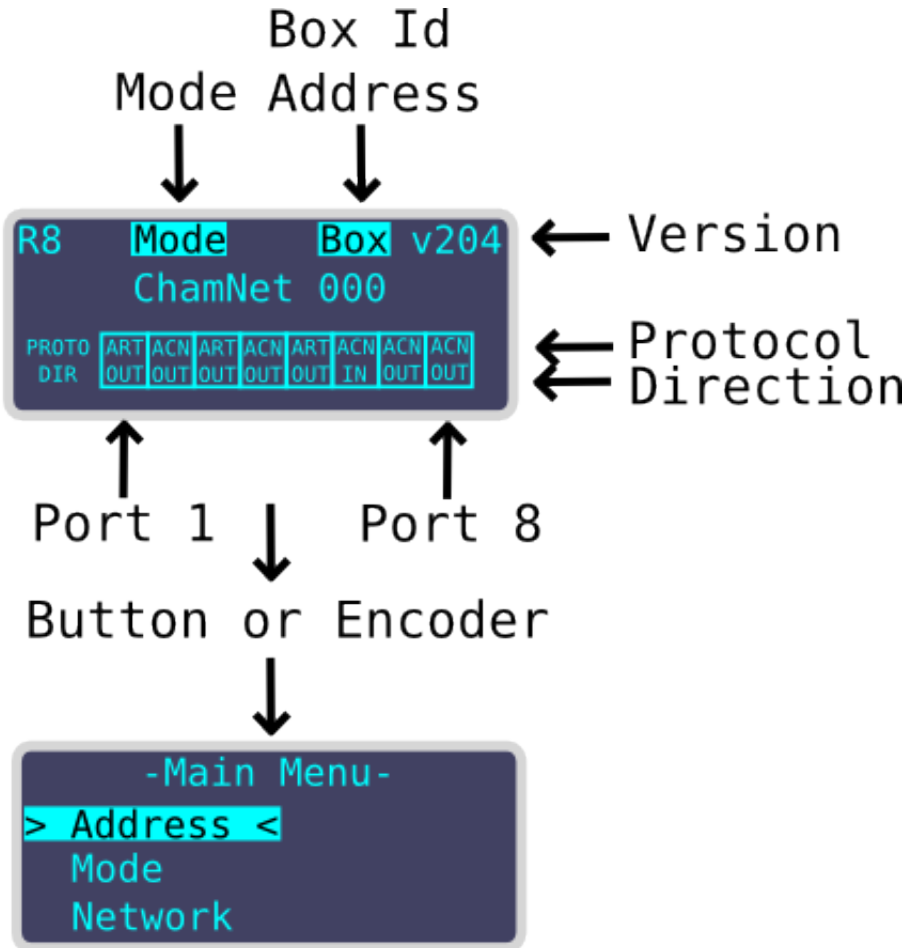

5.4.1 Main Menu

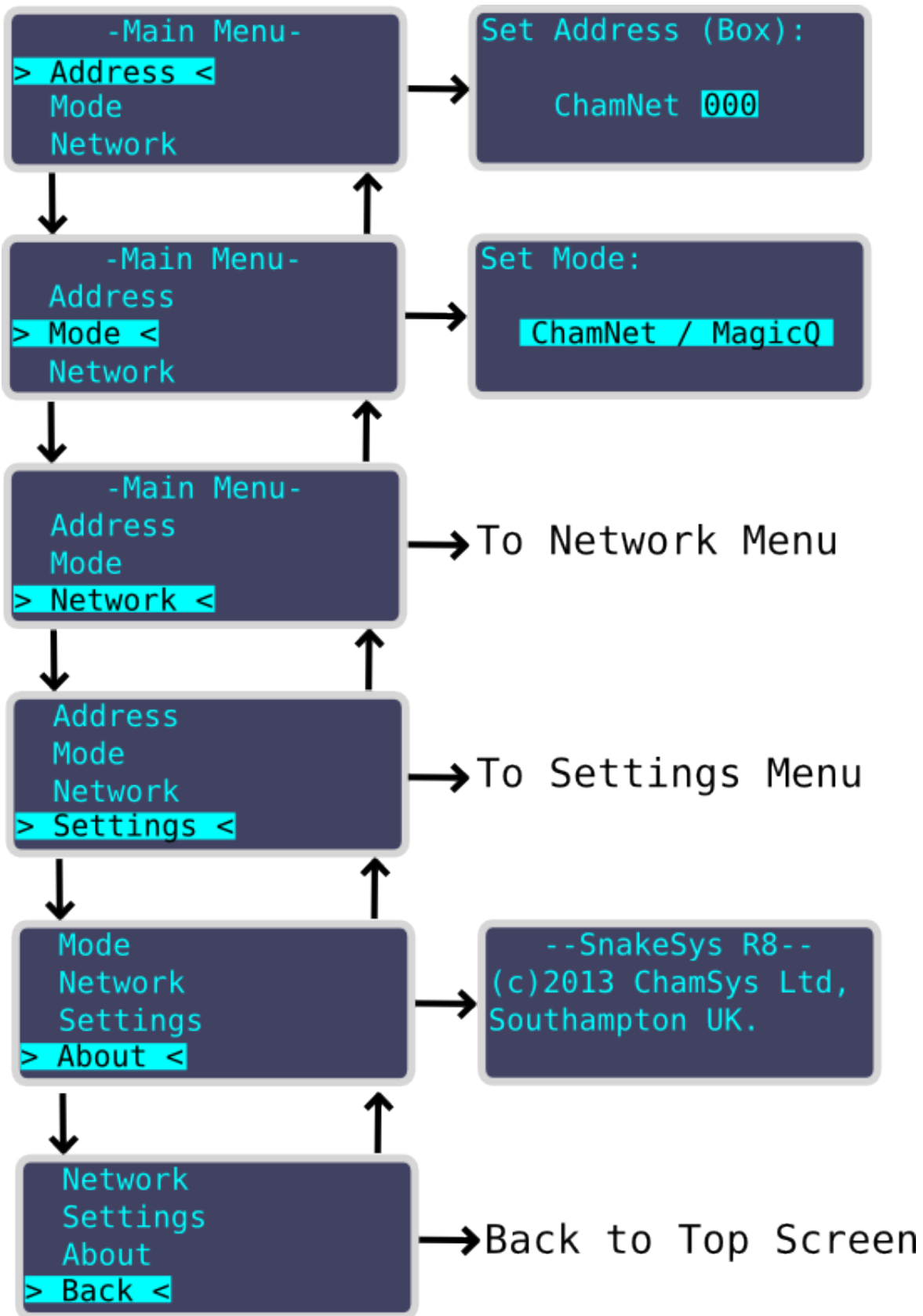

- **Address**

Used to set the R8 address / universe, which can be either:

Box Id	ChamNet Mode
Art-Net universe	Art-Net Mode
sACN universe	sACN Mode

- **Mode**

Used to set the network protocol mode used by the R8, which can be either:

Menu Item	Function
Disabled	No ports output or input
ChamNet/MagicQ	Ports controlled by MagicQ
Art-Net/Output	Ports 1 to 8 output Art-Net Mode
Art-Net/Input	Ports 1 to 8 input Art-Net Mode
ACN/Output	Ports 1 to 8 output sACN Mode
ACN/Input	Ports 1 to 8 input sACN Mode

5.4.2 Network Menu

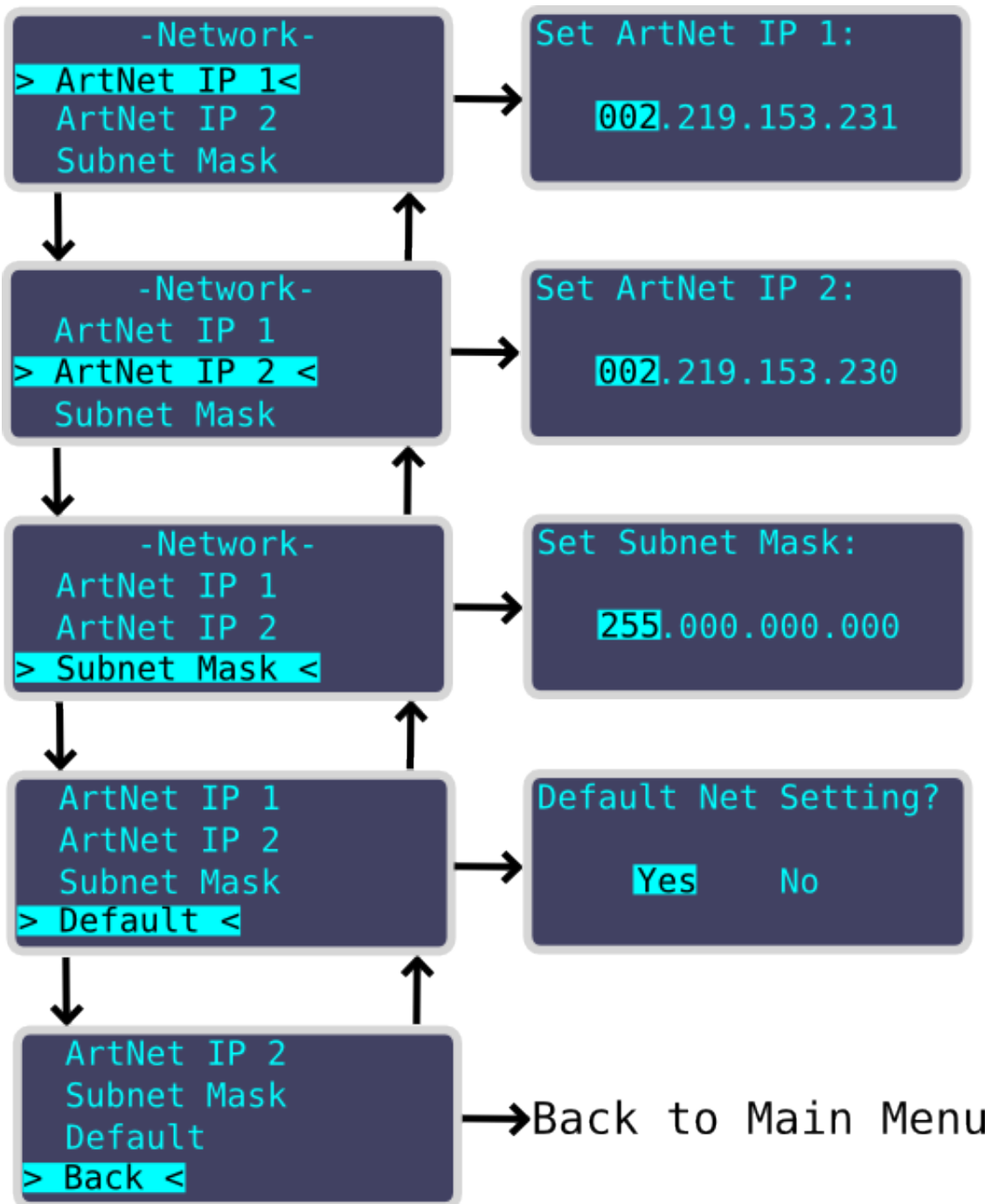

Menu Item	Function
ArtNet IP 1	Used to set the main R8 network IP address used by the R8 processor. If the unit is placed into Art-Net mode then this IP is used for Art-Poll-Reply / Art-Net DMX network data on ports 1 through 4. The main IP address is automatically chosen when the R8 units default settings are applied, however sometimes it is necessary to change the address. This is an advanced option.
ArtNet IP 2	Secondary IP address used only in Art-Net mode for Art-Poll-Reply / Art-Net. DMX network data on ports 5 through 8. The secondary IP address is automatically chosen when the R8 units default settings are applied, however sometimes it is necessary to change the address. This is an advanced option.
Subnet Mask	This is an advanced option, The default subnet mask is normally 255.0.0.0
Default	Used to restore default networking settings to the R8.

5.4.3 Settings Menu

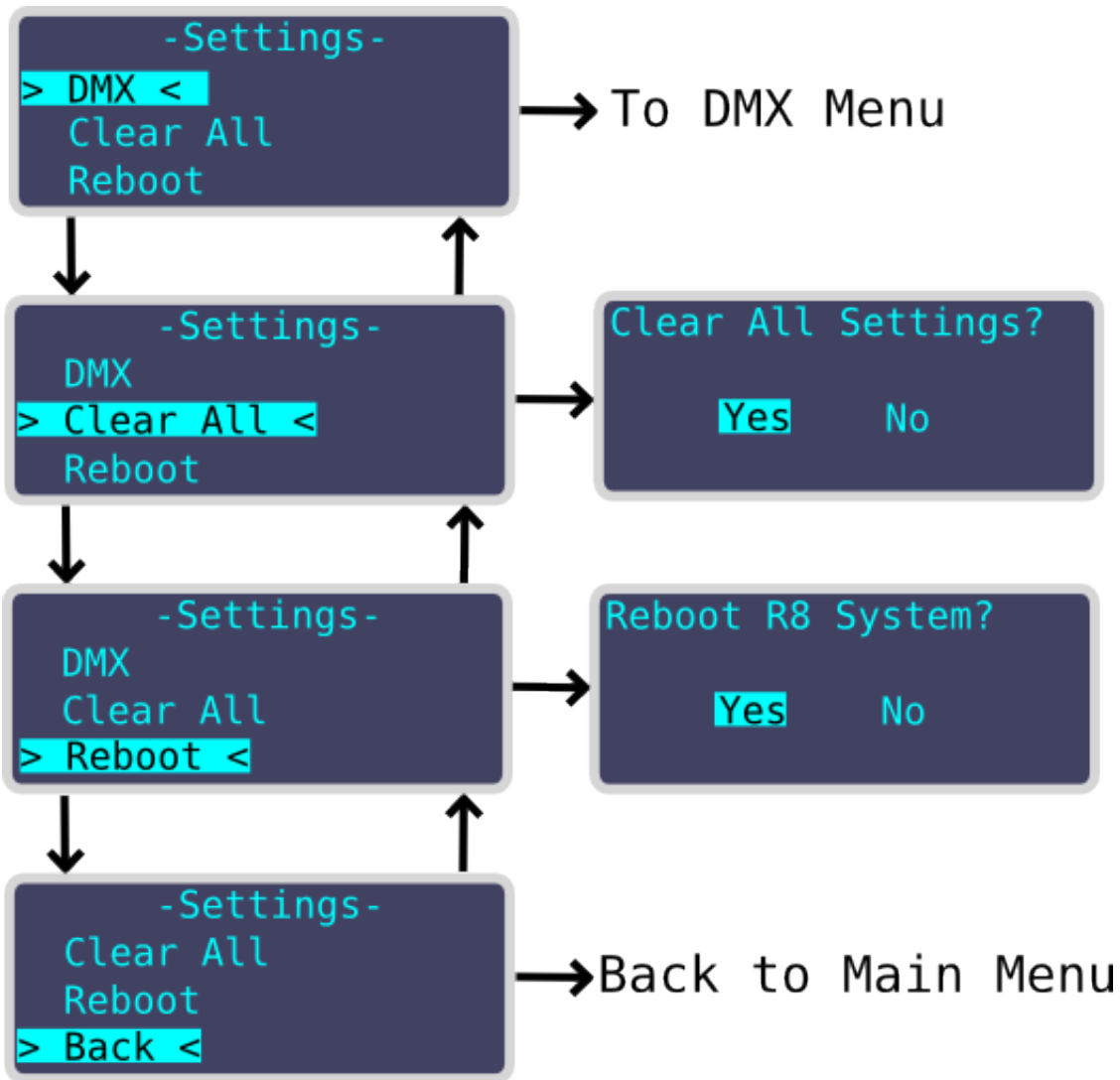

Menu Item	Function
Clear All	Used to clear all R8 settings, and restore the entire unit to factory default settings. The R8 will automatically reboot after default settings are restored.
Reboot	Used to completely reboot the R8 unit.

5.4.4 DMX Settings Menu



Caution

The following settings are a feature for advanced users which can be used if DMX timing related issues are found with certain fixtures. It is not recommended to adjust these features unless you are familiar with DMX packet and understand what the adjustments are actually doing.

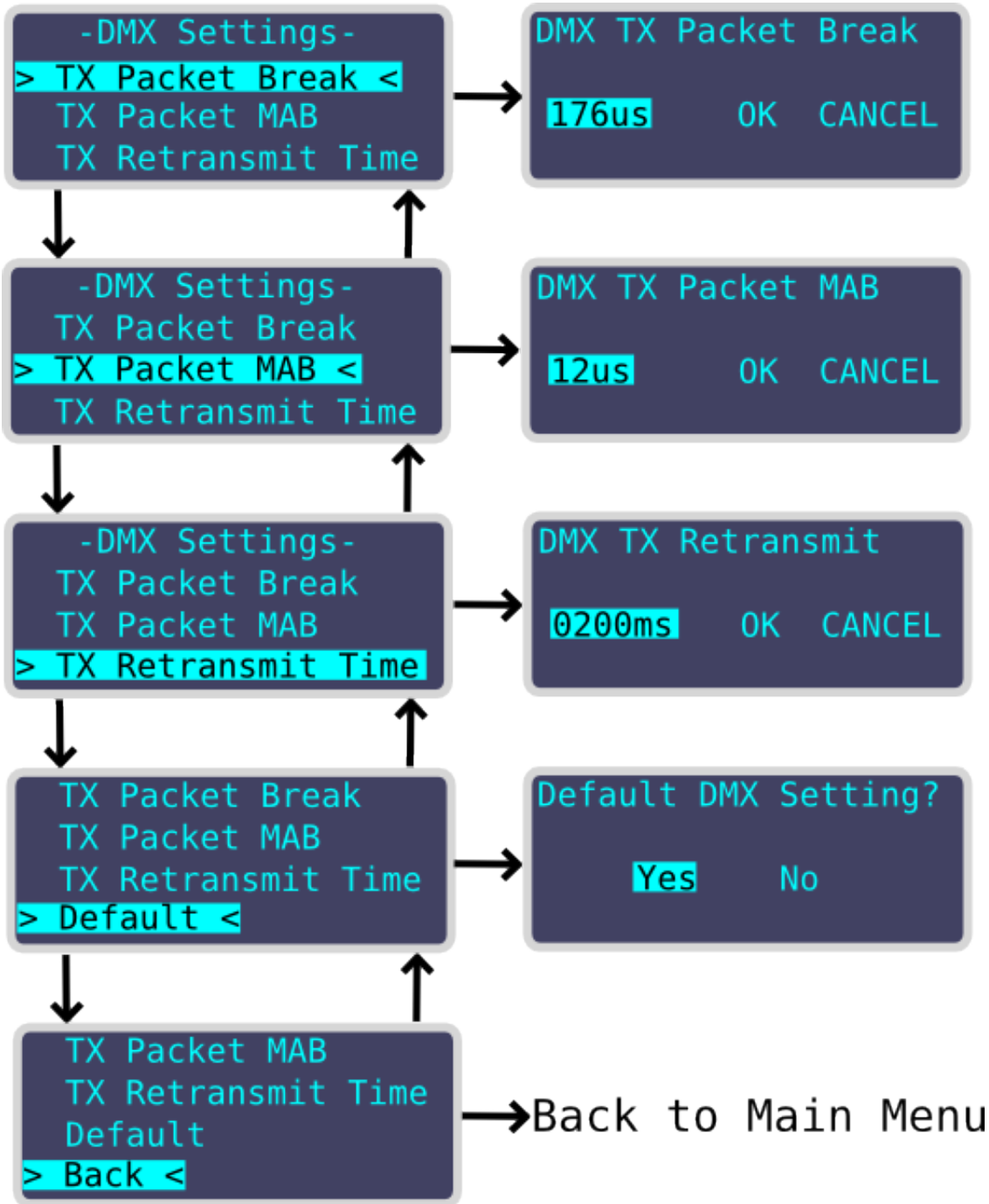

Menu Item	Function
TX Packet Break	Used to adjust the length of the transmitted DMX Break which is adjustable in microseconds

Menu Item	Function
TX Packet MAB	Used to adjust the length of the transmitted DMX Mark After Break which is adjustable in microseconds
TX Retransmit Time	When DMX network packets are not received this corresponds to the frame refresh delay between transmitted DMX packets to keep the DMX transmit alive, and is adjustable in milliseconds.
Default	This restores the DMX settings to factory default values. This is a useful feature to try if you experience issues with fixtures and are unsure what the DMX packet settings should be.

5.5 RDM Support

The R8 hardware supports full RDM functionality, however RDM is not currently supported in R8 firmware.

5.6 ChamNet Mode Information

In ChamNet Mode the SnakeSys R8 is configured and controlled from the Net Manager within MagicQ.

Note

The main IP address for the Interface can be reconfigured in Net Manager. It is not possible to change the secondary IP address from within Net Manager.

Note

The R8 unit will remember the settings that you make in MagicQ Net Manager. Please allow at least 40 seconds for the unit to store the information into flash memory before removing the power. If the unit is left in MagicQ ChamNet mode it will boot up with the settings that you made previously in Net Manager. (MagicQ will not be required to be connected via network to retain the settings).

5.7 Powering the SnakeSys R8

SnakeSys R8 is powered using the supplied Powercon cable.

The power supply is universal wide range input type and has the following specification: **85 to 264VAC @ 47 to 63 Hz or 120 to 370VDC**

The SnakeSys R8 does not have an internal battery.



Caution

During usage please ensure that the unit has adequate ventilation and that the cooling grilles on the unit are not obstructed.

5.8 Security Measure Warning

The R8 incorporates a number of advanced security measures to prevent copying and unauthorized reproduction of the firmware.

**Caution**

If user attempting repair of the PCB please do not use motherboard connector J3. Please also take care not to short out or touch any of motherboard connector J3 pins while the motherboard is powered up. Damage to the units firmware may result if the unit detects multiple tampering events, and the unit will have to be returned to ChamSys for reprogramming.

Chapter 6

Network Manager (SnakeSys)

MagicQ supports a Window for managing SnakeSys network products including the SnakeSys B4, SnakeSys R4, SnakeSys T2 and SnakeSys R8.

The Network Manager (Setup, View DMX I/O, Net Manager) can be used for monitoring and configuring SnakeSys products.

ID	Name	Status	Type	Config	Uni	IP Address	Subnet Mask	Mode Sw	Uni Sw	MAC Address	Firmware	Up Time	Sync	LED
---		Detected	Node4 Fixed	Art-Net Out	Art 0-0	2.211.102.139	255.0.0.0	0001	0	00:04:A3:12:66:8B	0100 (15064)	22s	Double	Normal

SnakeSys products can be configured in two different ways – in normal mode the product is configured from the front panel switches and buttons on the SnakeSys product. In ChamNet mode the switches and buttons are ignored and the product is configured from MagicQ.

6.1 Normal (non ChamNet mode)

If the SnakeSys product is set in a mode other than ChamNet Mode (such as Art-Net , ACN or buffer) then it is not possible to configure the interface from Net Manager. However, the device will still appear in Net Manager and it is possible to view its configuration.

6.2 ChamNet Mode (MQ Net)

In ChamNet mode each SnakeSys product on the network is considered to be a different interface with a different ID in the range 0 to 99. All interfaces should have different IDs.

The ID is set on the SnakeSys product using either the control panel or rotary switches.

The SnakeSys product can be configured using the CONFIG DEVICE soft button and selecting an appropriate profile.

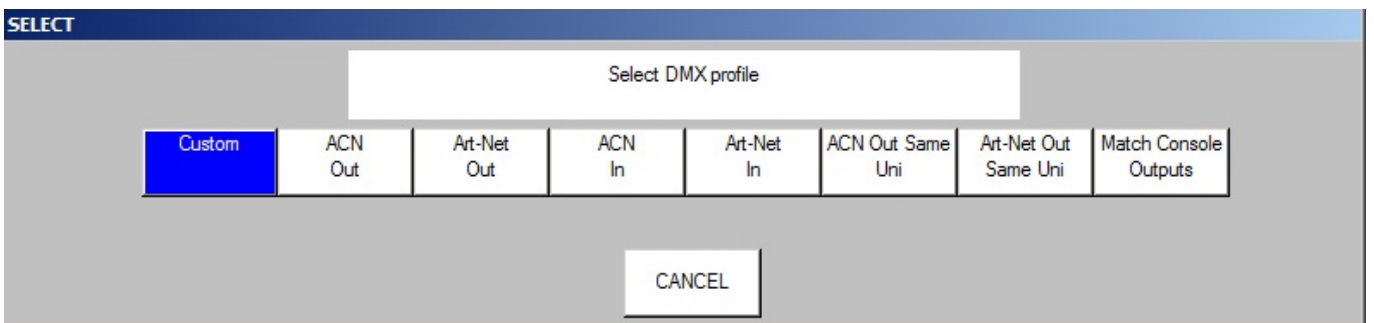

The profiles act as a starting point – once a starting profile has been chosen, the detailed configuration can all be set individually for each port by changing to the VIEW PORTS view.

VIEW DEVICES	VIEW PORTS	CLOSE WINDOW	INSERT DEVICE	CONFIG DEVICE									
NET MANAGER													
ID	Dev Name	Port	Port Name	Cons Uni	Config	Protocol	Uni	Length	Rate	Frame	MAB	Break	Status
CH 0	Box1	1	U1 Out	Out	Art-Net	Art 0-0	512	33Hz	56us	12us	176us	Up 0.04.00	
		2	U2 Out	Out	Art-Net	Art 0-1	512	33Hz	56us	12us	176us	Up 0.04.00	
		3	U3 Out	Out	Art-Net	Art 0-2	512	33Hz	56us	12us	176us	Up 0.04.00	
		4	U4 Out	Out	Art-Net	Art 0-3	512	33Hz	56us	12us	176us	Up 0.04.00	
		5		None	None		512						

The rate, frame, MAB and Break timing can be set for each interface – the timings affect all ports on the interface.

When configured as Outputs the ports can be configured to output the same or different Art-Net / ACN universes.

The Cons Uni field shows the console universe on MagicQ that is outputting the data that the port is trying to read. If no console universe is set to output on that port then the field is blank.

At any time you can revert back to a standard profile by pressing the CONFIG DEVICE soft button – this will show the list of DMX profiles.

6.3 Upgrading SnakeSys firmware

SnakeSys product firmware can be firmware upgraded from MagicQ software - the latest MagicQ software contains the latest firmware for all SnakeSys products - this can be found in the firmware folder under on the installation.

ChamSys recommend not attempting a firmware update on SnakeSys products in a critical show environment.

Download the latest MagicQ software from the ChamSys download site. In order to upgrade the full range of SnakeSys devices MagicQ must be running software version 1.6.0.5 or higher.

<http://chamsys.co.uk/download>

- Connect the SnakeSys device to either a MagicQ Console or MagicQ PC/Mac System via a direct network cable. It is advisable to remove all other equipment from the network.
- SnakeSys devices ship with a default IP address in the 2.X.X.X range, in order to update the firmware on your device MagicQ must also be set to an IP address within this range.
- Set the SnakeSys device to be in ChamNet/MagicQ mode
- In Net Manager, put the cursor on the device to be upgraded and press UPGRADE DEVICE.
- Choose the required firmware version. In older versions of MagicQ you need to specify the version number of the firmware.
- Do not power off the interface whilst the firmware is being upgraded. When MagicQ reports "Device restarted successfully" the upgrade is complete.

VIEW DEVICES	VIEW PORTS	CLOSE WINDOW	CONFIG DEVICE	INSERT B4 MK1	UPGRADE DEVICE		
NET MANAGER							
ID	Name	Status	Type	Config	Uni	IP Address	Subnet Mask
CH 99	SnakeSys R4	Detected	Box B4 ChamNet	Custom	Art 0-0	2.9.200.6	255.0.0.0

If you are sent a newer firmware file by ChamSys support then copy the file into the firmware folder in the MagicQ installation. To install it onto a MagicQ console put the file onto a USB stick, then in MagicQ go to Setup, File Manager. Select USB DRIVE. Press COPY and select the file as the source to copy. Then select the destination, by selecting HARD DRIVE, UP DIR, and select the firmware folder. Press the "." item to copy to. Then follow the procedure above.

The firmware has the filename firmware_XXXX_YYYY where the XXXX is the product code and YYYY is the firmware version number. The product codes are:

- SnakeSys B4 334A
- SnakeSys R4 342A
- SnakeSys T2 419B
- SnakeSys R8 330A

6.4 Older ChamSys 4 Port Ethernet interfaces

Older Chamys 4 Port Ethernet Interfaces and the SnakeSys B4 interfaces manufactured prior to 2013 (serial numbers with last 4 digits less than 0268) have no storage for configuration data and so when in ChamNet mode they always get their configuration from MagicQ every time they are powered up.

When the interface starts up it will recognise that it is in MQ Mode and then will search on the network to find a MagicQ system that can give it a configuration. The interface will not output or input DMX data until it has received configuration from a MagicQ system.

The MagicQ system stores the configuration information for all these older interfaces as console settings. In View Ports, press the INSERT B4MK1 button to add a new interface. MagicQ will present a list of default profiles for configuring the interface.

An interface can be removed by putting the cursor on the line of the interface and pressing REMOVE.

If there are multiple MagicQ consoles on the network, then only the master one (as per Hot Takeover) will provide configuration information to the interfaces.

Newer SnakeSys B4s and all other SnakeSys products will appear automatically in the list and do not need to be inserted or removed.

6.5 Output Setup

In order to use a SnakeSys product with a MagicQ system the MagicQ system must be set up in Setup, View DMX I/O to output or input universes over the network

When outputting from the SnakeSys product set up MagicQ universes with Output type of Art-Net or ACN with the Out Uni set to the Art-Net or ACN universes that the SnakeSys device is set to decode.

For inputting DMX from the SnakeSys product set up MagicQ unvierverses with Input type of Art-Net or ACN with the In Uni set to the Art-Net or ACN universes that the SnakeSys device is set to generate.

Chapter 7

SnakeSys Firmware Release Notes (B4, R4, T2)

7.1 Version V213

7.1.1 All Products (Improve Policy For Save Of Settings)

Reduced the required time that the user needed to wait for units to save their Net-Manager DMX port settings to flash memory from 30 seconds to 15 seconds.

Network IP and Subnet-Mask settings that are adjusted from the Net-Manager are now saved to flash memory immediately.

Synchronisation settings were not previously saved, they are now saved immediately to flash after adjustment via the Net-Manager.

Fixed a bug which caused a longer delay than expected before settings were written to flash memory.

7.2 Version V212

7.2.1 SnakeSys B4

Fixed issue when using Art-Net and ACN subnets 3-0 and above which would cause the DMX packet to be reduced to less than the full 512 values. This potentially affects all versions V200 to V211 but was most noticeable in V210 and V211.

The above issue would also cause the DMX framing timings to be erroneously adjusted from the defaults when using Art-Net and ACN start universe above universe 0-0 up to universe 2-15. The DMX output was within spec but could be slower than expected. In Art-Net and ACN mode the subnet and universe selection were incorrectly being used to apply the timing settings from the buffer mode (as per the rear panel legend).

Fixed break interrupt issue with DMX input which was introduced in V211.

Changed operation of DMX in LED to work like the other products.

7.3 Version V211

7.3.1 SnakeSys T2 Version 2

Added support for T2 Version 2 with DMX input option.

Added PCB version dependent menu items.

7.4 Version V210

7.4.1 SnakeSys R4

Increased timeout value for DMX input LED display.

Added optional software based break detect and also added DMX special mode to allow software based break detect:

R4 now has the ability to switch between hardware break detect or software break detect, so users who experience the CPLD.v1 break detect issue can still get the unit to receive DMX correctly: This is done by holding the DMX button on the front-panel for 5 seconds until it starts flashing. Once the button is flashing pressing the NET1 button will toggle between both break detect types:

NET1 Illuminated: Software break detect NET1 Off Hardware break detect

Pressing again the DMX button will exit back to standard front-panel operation, and the state will be saved.

7.4.2 All Products

Fixed a timing issue with DMX receive where the output packet update did not take place until the next packet's break was received. This could cause latency problems on systems with slow DMX refresh.

7.5 Version V209

7.5.1 All Products

Applied the Art-Net output hold fix to DMX to always hold the DMX output after valid Art-Net has been received and output as DMX.

7.6 Version V208

7.6.1 SnakeSys T2

Support for SnakeSys T2 added.

7.7 Version V206

7.7.1 SnakeSys B4

Added support for storing of ChamNet settings.

7.8 Version V204

7.8.1 Snakesys R4

Fixed a bug where when the units settings were reset from the front-panel the POE ports were disabled. Since there is still no way to re-enable the ports in MagicQ this could be a serious issue for some end users.

Fixed a bug where the PoE ports were not turned off when the unit was placed in standby mode.

Changed operation of RDM filter button to match that of ART/ACN and IN / OUT with respect to ChamNet mode

7.8.2 Snakesys B4

Enabled break detect on DMX input

7.9 Version V203

7.9.1 Snakesys B4

Modified DMX input so that it can be enabled when outputs 1-4 are active

7.10 Version V202

7.10.1 Snakesys R4

In ChamNet mode the IN/OUT and ART/ACN LEDs now reflect the current ChamNet settings, and will toggle if combined protocol or input / outputs are used.

7.10.2 All Products

Added notifications so MagicQ can detect when port settings are changed.

7.11 Version V201

7.11.1 Snakesys R4

Changed the operation the following buttons so that ChamNet does not get disabled when they are pressed:

DMX IN/OUT ART/ACN RDM FILTER

Fixed an issue with the thermal management regarding the fan, which now has a programmed minimum fan speed of 1500RPM, and starts instantly on power up, and also improved the fan control system and sample rate.

7.11.2 All Products

ART: Updated the Art-Poll Reply packet to correctly report the products short and long names.

ACN: Minor change to the header to reflect a tiny version of the product name.

7.12 Version V200

Version 2 framework supporting both R4 and B4.
