

mSCULPT 20 LED Profile

Mini LED Ellipsoidal



Information specifically for:

TH-SCLPM20WW/B

TH-SCLPM20QW/B

TH-SCLPM20QA/B

This manual contains important information.
Please read before operating fixture.



V2.1

IMPORTANT INFORMATION

Save original packing and documentation for warranty, service and return issues.

Limited Warranty: This warranty covers defects or malfunctions in this equipment. This warranty lasts for a period of two years from date of purchase. It is the owner's responsibility to provide invoices for proof of purchase, purchase date and dealer or distributor. If purchase date can not be provided, warranty period will start at manufacture date. It is the sole discretion of Techni-Lux to repair or replace parts or equipment. All shipping will be paid by purchaser. This warranty does not cover lamps, fuses, belts, power semiconductors, relays, cleaning, standard maintenance adjustments or normal wear items or any problem resulting from the following: improper wiring, incorrect voltage (including low or over voltage conditions and lightning), abuse, misuse, improper maintenance or an act of God or damage resulting from shipping. Warranty will be null and void if the product is altered, modified, misused, damaged, or subjected to unauthorized repairs. Lamps are covered by relevant manufacturer warranty. This warranty gives you specific legal rights, and you may also have other rights which vary from state to state. Any liability for consequential and incidental damages is expressly disclaimed. No other warranty, expressed or implied is made. Techni-Lux liability in all events is limited to, and shall not exceed, the purchase price paid.

Returning equipment and Repairs: All returns must be accompanied by a Return Merchandise Authorization (RMA) number and sent pre-paid. Contact the dealer or Techni-Lux directly to obtain an RMA. The RMA number must be clearly listed on the shipping label. Due care must be exercised in packing all merchandise to be returned. All repairs must be accompanied by a written explanation of the claimed problem or error encountered. Techni-Lux is solely responsible for determining a product's eligibility for coverage under warranty. If returning for consideration of credit, all accessories and documentation, original protective material and cartons must be included and the equipment, packing and carton must be in new resalable condition. Credit for returned merchandise will be issued at the lowest current price and is subject to a restocking fee. No returns accepted on discontinued items. Techni-Lux is not responsible for merchandise damaged in transit and reserves the right to refuse any return that is damaged by the carrier, not accompanied by a Return Authorization Number (RMA#) or sent by freight collect.

Claims: All claims must be made within seven (7) days of receipt of merchandise. Any physical damage must be reported to carrier upon receipt of merchandise.

Please record the following information for future reference:

Model Number: TH-SCLPM20WW/B, TH-SCLPM20QW/B or TH-SCLPM20QA/B

Serial Number: _____

Dealer: _____

Date of Purchase: _____

Table of Contents

Specifications	4
Unpacking	5
Purpose of Manual	5
Power	5
Basic Reference	6
Mounting	6
Installing Lens Barrel	7
<i>Beam Chart</i>	<i>7</i>
Accessory Slot and GOBO Holder	8
<i>Gobo Size</i>	<i>8</i>
Basic Setup Wiring Diagrams	8
Fixture Menu Display & Buttons	9
<i>TH-SCLPM20WW Menu Settings</i>	<i>9</i>
<i>TH-SCLPM20QW or QA Menu Settings</i>	<i>9</i>
DMX-512 Control	10
<i>DMX Data Connection</i>	<i>10</i>
<i>Data Terminator</i>	<i>10</i>
<i>Adapters for 3 or 5 pin XLR</i>	<i>11</i>
<i>DMX Start Address</i>	<i>11</i>
DMX Channel Assignments and Values	12
<i>WW Channel Layout (for model TH-SCLPM20WW)</i>	<i>12</i>
<i>QW Channel Layout (for model TH-SCLPM20QW)</i>	<i>12</i>
<i>QA Channel Layout (for model TH-SCLPM20QA)</i>	<i>12</i>
Maintenance	13
Troubleshooting	13
DMX-512 Background	14
Accessory Items (sold separately)	15

Specifications

Fixture Overview

- 20w SSL COB LED
- Heatsink Cooling Block – No Fan
- Flicker-Free Output for Film/TV/Video
- Warm White 3000k with CRI >93
- DMX, Standalone
- 5 Pin XLR Data Connectors
- Low voltage 12vDC power input
- LED Display Menu for settings
- Barrel rotation and shaping shutter blades

Physical

Color	Black
Size	8.75" L x 6.22" W x 8" H (222x158x203mm)
Weight	2.42 lbs. (1.1 kgs)
Housing Material	Aluminum & ABS

Environmental

Location	IP20 Indoor
Min/Max. Ambient Temperature	-5 to 113°F (-20 to 45°C)
Min. distance to flammable surface	3.3 ft (1.0 m)
Min. distance to illuminated surface	1.0 ft (0.3 m)

Electrical

Voltage	12v DC
Rated Power	22W
Connection	DC coaxial connector
Rating Approval	CE

Control

Digital Protocol	USITT DMX512 (1990)
Channels	2 for WW, 8 for QW or QA fixtures
Data I/O	5 Pin XLR In and Pass Thru
Modes	DMX512, Manual/Stand-Alone

Optics

Light Source	20W COB LED – 1590 to 2535 Lumens
Color(s)	WW (3000k) CRI >93, QW (RGBW), or QA (RGBA)
Gobo Size (Optional)	Outer Diameter - OD 38 mm, Image Area - IA 28mm
Beam Angle	14°, 19°, 26°, 36° (lens required, sold separately)

Rigging

Orientation	Any
Mounting Points	Angle adjustable yoke with 7/16" (11mm) Mounting Hole

Unpacking

Immediately upon receipt, carefully unpack and inspect the fixture to verify that all parts are present and have been received in good condition. If any parts appear damaged or the shipping carton shows signs of mishandling, notify the shipper immediately. Retain carton and all packing material for inspection. In the event that the merchandise is to be returned, the original carton and packing must be used. The customer will be billed for a new carton and packing if merchandise is received without the original carton and packing.

Claims

It is the customer's obligation to notify the Freight Carrier or Shipping Company of any physical damage or signs of mishandling immediately upon receipt. Damage incurred in shipping is the responsibility of the Freight Carrier or Shipping Company. All other claims not related to damage incurred during shipping must be made to the Dealer or Distributor within 7 days of receiving merchandise.

Returns

Returned merchandise must be in the original packing with a Return Merchandise Authorization number (RMA) clearly listed on the shipping label. Items sent by Freight Collect or without a RMA number will be refused. Call your seller and request a RMA prior to shipping. Be prepared to provide the model number, serial number and a description of the nature of the return. Shipping damage resulting from inadequate packaging is the customer's responsibility. Customer will be charged additional shipping charges to return products received in non original packing and or cartons.

Purpose of Manual

The purpose of this manual is to explain the necessary steps for using this fixture properly and to assure peak performance of said product functions. It is intended for use as a reference by a fully qualified electrician, technician and lighting professional. This manual should never be considered a substitute for any provision of a regulation, state, and/or local code. The responsibility of complying with all state and local laws, ordinances, and regulations in regards to installation, maintenance, and operation of this product lies with the buyer and handler of the product. The instructions and precautions set forth in this manual are not necessarily inclusive of or relevant to all applications. Please read the entire manual to fully understand and safely use this product.

Power



Do not apply power to the fixture without verifying power source. For protection against electric shock, do not attempt to use if fixture appears damaged or is not connected to suitable earth ground. Disconnect from power mains before any service.

This fixture operates on 12vDC. The included transformer automatically adjusts to mains voltage and frequency within the specified range and outputs 12vDC. Before applying power, check that the power source is within the fixture's specified range. The listed power rating is its average wattage under normal conditions. All fixtures must be powered directly from a switched circuit. This fixture cannot be run on a rheostat or dimmer circuit even if used solely for a 0% to 100% switching. Consult a qualified electrician if there are any concerns about proper connection to power.

Basic Reference

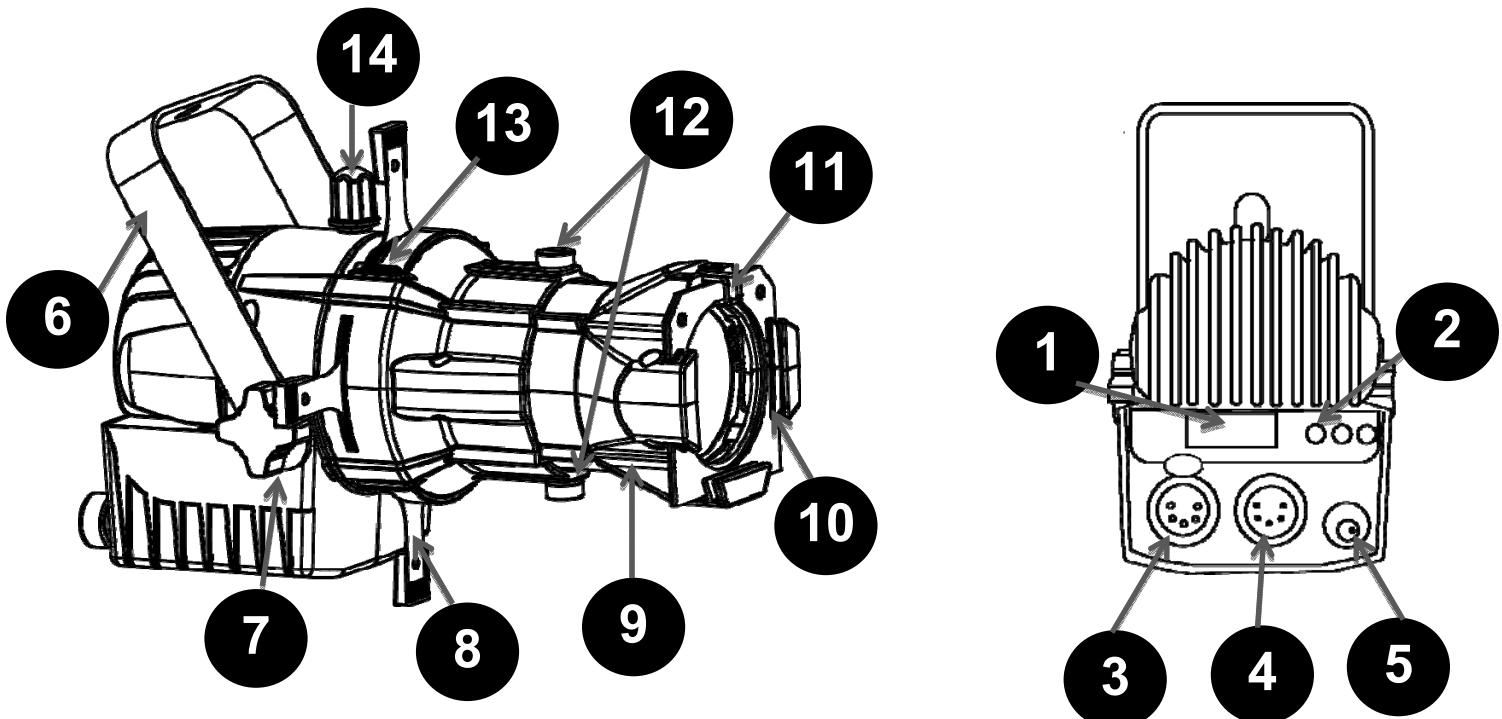

1	LED Display	8	Framing Shutters x4
2	Menu Buttons	9	Lens Barrel (Not Included)
3	Data Out	10	Color Frame Slot
4	Data In	11	Color Frame Locking Clip
5	Power Input	12	Focus Knob x2
6	Yoke	13	Accessory / Gobo Slot and Cover
7	Yoke Knob x2	14	Lens Barrel Rotation/Removal Knob

Mounting

Consult a qualified professional before rigging and mounting. Consider access for routine maintenance, adjustments, minimum distances and to prevent restricted ventilation, exposure to water, high humidity, and extreme temperature changes. Fixture may be mounted in any orientation provided appropriate clamp is used to mount securely. Secure all cables properly and keep away from hot surfaces to prevent heat damage and trip hazards. Do not obstruct any vents.

Installing Lens Barrel

A Lens Barrel is required but sold separately to combine with the fixture and are interchangeable. This Lens Barrel determines the Beam Angle of the fixture. Select the angle best suited to the application.

TA-SCLPMLENS/14	14 degree for mSculpt Profile
TA-SCLPMLENS/19	19 degree for mSculpt Profile
TA-SCLPMLENS/26	26 degree for mSculpt Profile
TA-SCLPMLENS/36	36 degree for mSculpt Profile

To install Lens Barrel:

1. Unscrew the two Focus Knobs from the Lens Barrel.
2. Choose the orientation that puts the Color Frame Locking Clip is in the most 'up' position to prevent color frames from accidentally falling when unlocked.
3. Reinstall Focus Knobs, adjust lens back and forth to set desired focus, and tighten knobs.

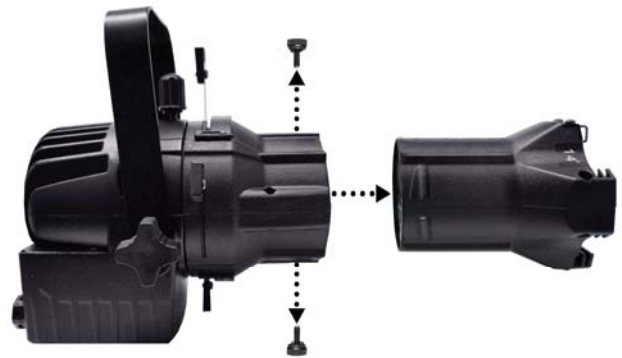

Beam Chart

Approximate Diameter at Distance for given Beam Angle (feet or meters)

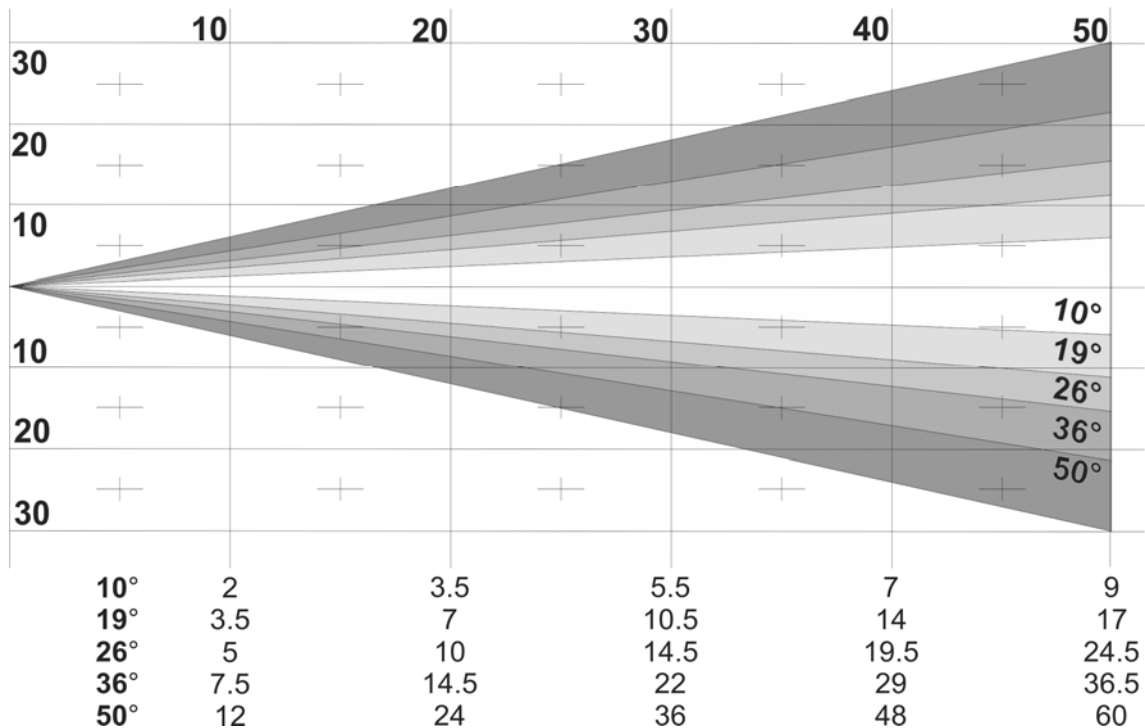

Accessory Slot and GOBO Holder

The Accessory Slot is located under a sliding plate fixed by two screws. When nothing is installed this cover prevents light spillage from the fixture. Under the cover are two different sized slots. The larger slot can accept accessories like Irises or GOBO rotators. The smaller slot is generally reserved for fixed GOBO holders and variants are available to accommodate either metal or glass gobos.



Gobo Size

Outer Diameter
38 mm

Image Area Diameter
28 mm

Basic Setup Wiring Diagrams

There are two basic ways to use the fixture. One is in standalone, which does not require the use of any data lines to be connected nor any controller, each fixture would operate independently based solely on the menu setting. The second method, is to use the units in DMX control. The second method requires the fixtures to be wired together via the DMX DATA in and out cables. This allows the units to receive data either from the master unit or the DMX controller. Data wiring is explained in more detail in the DMX Data Connection section of this manual.

Example Block Diagram

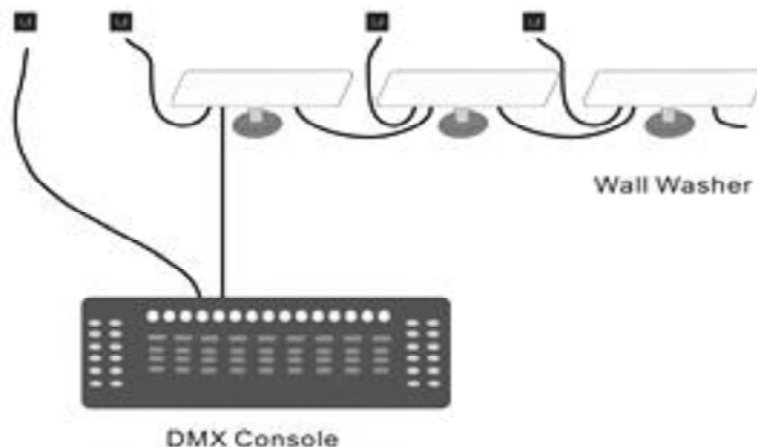

Fixture Menu Display & Buttons

Use the 3 buttons and display panel located on the rear of the fixture to access fixture settings.

Press the ESC/Enter button to select an option then again to Save and exit.

Use the DOWN/UP buttons to move through the menu and to increase or decrease a value or change the option.



TH-SCLPM20WW Menu Settings

MENU	Display	Options	Description
Address	Address	001-511	DMX Start Address – shows the DMX start address the unit is set to
Dimmer W	White	000-255	White Dimmer Level – used to manually set an output level when not using DMX
Demo	demo	Sc00-02	Demo Scenes – two demo looks to choose from when no DMX control
Master	Master	On/off	Master Mode – default is Off. When On, unit outputs the current settings

TH-SCLPM20QW or QA Menu Settings

MENU	Display	Options	Description
Address	Address	001-511	DMX Start Address – shows the DMX start address the unit is set to
Dimmer W or A	White	000-255	White or Amber Level – used to manually set an output level when not using DMX
Dimmer R	Red	000-255	Red Level – used to manually set an output level when not using DMX
Dimmer G	Green	000-255	Green Level – used to manually set an output level when not using DMX
Dimmer B	Blue	000-255	Blue Level – used to manually set an output level when not using DMX
Demo	demo	Sc00-15	Demo Scenes – 15 demo looks to choose from when no DMX control
Master	Master	On/off	Master Mode – default is Off. When On, unit outputs the current settings

DMX-512 Control

Fixtures require a "Start Address" from 1 to 512, setting the first DMX channel containing data for the fixture (see DMX Background). Before addressing fixtures, consult the manual of the system's DMX controller to select a desirable addressing scheme. Valid Start Addresses range from 1 to 512. Fixtures requiring more than one channel for control will read subsequent channels up to the total number of channels required. Since this fixture requires a maximum of 10 channels of DMX, if set to a Start Address of 11 it would use data from channels: 11, 12, 13, 14, 15, 16, 17, 18, 19, and 20. Choose a Start Address so the channels used do not overlap with other fixtures. In some cases, it may be desirable to set two or more same type fixtures to the same Start Address. In this case, the fixtures will be slaved together and respond to the same data. Because all fixtures see the same data, fixtures may be set to any address without concern for the order they are connected by the DMX cables.

DMX Data Connection

This fixture uses XLR type connectors. Use shielded twisted pair cable approved for EIA-422/EIA485 use. Fixtures are connected in Daisy Chain topography: Connection is made from the controller to the DMX-IN of the first light, then from the DMX-OUT to the DMX-IN of the next light and so on. Only one data source can be on a chain and no branching is allowed. The physical order in which the fixtures are connected is not important, use the most convenient.

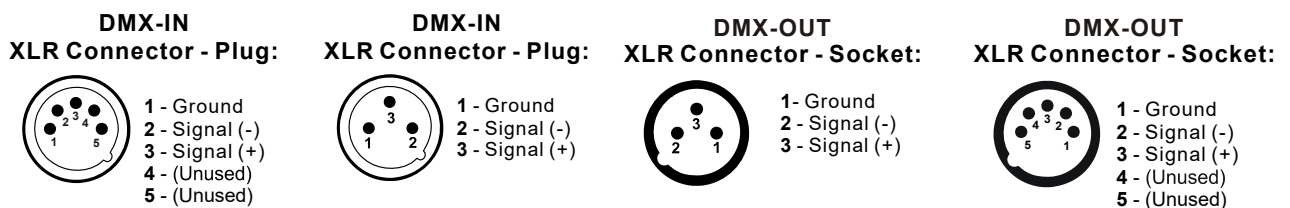

Data Terminator

A Data Terminator can be purchased to connect to the DMX-OUT of the last fixture to reduce the effects of signal noise. To make a Terminator, connect a 120-ohm ¼ watt resistor across pin 2, Data Negative (S-) and pin 3, Data positive (S+). A qualified technician can determine if a Data Terminator is required.

Adapters for 3 or 5 pin XLR

Systems using a mix of 3 and 5 pin XLR DMX interfaces can be accommodated by purchasing adapters or building adapter cables. Numbers designating each pin can be found on connectors. Converting between the two XLR types is done pin-to-pin. Shield wire connects to pin 1, then connect pin 2 to pin 2 and pin 3 to pin 3, regardless of either connector's gender or pin count. No connection is made to Pins 4 & 5.

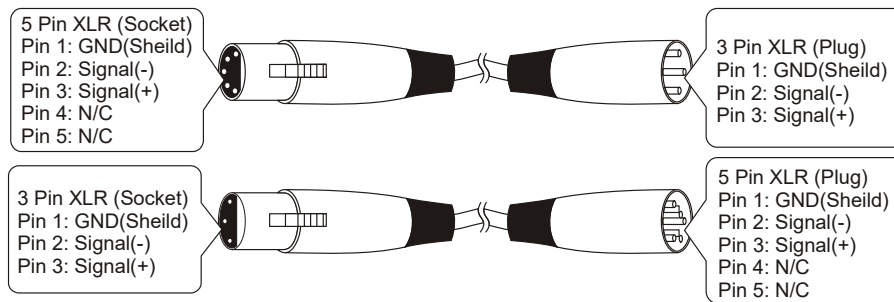

DMX Start Address

More than one fixture may have the same start address, but they will behave the same. Giving a unique start address that does not overlap with any other units allows you to individually control that fixture's features fully. Never allow channels to overlap. This fixture features a 3 channel DMX mode. This will determine the spacing of channels you will need to avoid overlapping of channels when selecting your start addresses.

Example Select Start Addresses for 4 fixtures each requiring 2 channels of DMX.

For this example, start with the first unit set to the first possible Start Address = **1**. This fixture occupies DMX channels 1 thru 2. The next DMX channel available for a Start Address is found by adding the previous fixture's Start Address to its channel requirement: $1+2=3$. To maximize channel usage leave no empty channels between fixtures, so the second Start Address is set to DMX channel 3 and that fixture occupies channels 3 thru 4. The third fixture will be addressed $3+2=5$ and occupy channels 5 thru 6. The last fixture is addressed $5+2=7$ and will occupy channels 7 thru 8. Thus, 4 fixtures using 2 channels each have Start Addresses of **1, 3, 5** and **7**, leaving the next free channel in the system is $7+2=9$.

DMX Channel Assignments and Values

WW Channel Layout (for model TH-SCLPM20WW)

2 CHANNELS					
Channel	Function	Values			Description
1	Dimmer	000	-	255	Dimmer Intensity 0 - 100%
2	Shutter Strobe	000	-	255	Strobe Speed Open to Fastest

QW Channel Layout (for model TH-SCLPM20QW)

8 CHANNELS					
Channel	Function	Values			Description
1	Dimmer	000	-	255	Dimmer Intensity 0 - 100%
2	Shutter Strobe	000	-	001	Shutter open
		002	-	127	Strobe effect with increasing speed
		128	-	159	Strobe effect with increasing speed
		160		191	Pulse effect with increasing speed
		192	-	255	Random strobe effect with speed
3	Macro Effect	000	-	255	Rainbow effect
4	Macro Speed	000	-	255	Rainbow speed
5	Red	000	-	255	Red Intensity Level 0-100%
6	Green	000	-	255	Green Intensity Level 0-100%
7	Blue	000	-	255	Blue Intensity Level 0-100%
8	White	000	-	255	White Intensity Level 0-100%

QA Channel Layout (for model TH-SCLPM20QA)

8 CHANNELS					
Channel	Function	Values			Description
1	Dimmer	000	-	255	Dimmer Intensity 0 - 100%
2	Shutter Strobe	000	-	001	Shutter open
		002	-	127	Strobe effect with increasing speed
		128	-	159	Strobe effect with increasing speed
		160		191	Pulse effect with increasing speed
		192	-	255	Random strobe effect with speed
3	Macro Effect	000	-	255	Rainbow effect
4	Macro Speed	000	-	255	Rainbow speed
5	Red	000	-	255	Red Intensity Level 0-100%
6	Green	000	-	255	Green Intensity Level 0-100%
7	Blue	000	-	255	Blue Intensity Level 0-100%
8	Amber	000	-	255	Amber Intensity Level 0-100%

Maintenance



Make sure fixture is cool and disconnected from power mains before any service.

Weekly operating hours and environmental conditions will establish how often the fixtures need cleaning. Fixtures should be cleaned and inspected at least once a month to maintain optimum performance. Accumulation of dust and fog residue increases heat build up, can lead to malfunctions, overheating and reduction in maximum light output, reduced fixture life and over all performance. Before conducting any maintenance, disconnect fixture from power mains.

- 1) Disconnect fixture from power mains.
- 2) Use a vacuum with a soft brush to remove dust collected on external vents and internal components. If using an air compressor, use low pressures and extreme care to prevent damaging any internal parts or effects.
- 4) Clean all optical elements when the fixture is cold. Use a soft lint free cotton cloth or tissue and cleaner safe for plastics.
- 5) Inspect clamps and safety cables to ensure fixture is secure and safe.

Troubleshooting

Diagnostic technique for DMX issues: Set suspect fixture's Start Address the same as a correctly functioning fixture. If both units then function correctly, issue is programming.

Symptom	Possible Cause / Solution
No Power	Check for power on mains
	Check power cord inserted correctly
Erratic / No response to DMX	Check data cables: connection and proper wiring
	Check Display, fixture in DMX512 Mode
	Verify Start Address of Fixture
Incorrectly responds to DMX	Check for overlapping addresses
	Check Fixture Channel Mode
	Check Menu settings
	Cycle Power and Retest
No Output or Image Partially Obstructed	Check Framing Shutter positions
Image is Backwards	Flip Gobo orientation in GOBO Holder

DMX-512 Background

DMX-512 is a digital data transmission standard developed by the United States Institute for Theater Technology (USITT). It is designed to enable control of lighting equipment. DMX deals solely with the formatting of data for transmission and does not dictate how the data is created or used.

Under DMX, signals are transmitted in much the same way a computer modem transmits data. The Data, divided into channels, is "Framed" using a start bit, high (1), eight data bits and finally, two stop bits, both high (1). DMX uses no parity to check the integrity of the signal. Instead, DMX relies on the ultra low probability of an error occurring in the same place when the data is resent. The rate at which data is sent is fixed at 250k bps, almost four and a half times faster than a 56k modem. This speed allows all data on a DMX chain to be updated more than 44 times every second.

The transmitted data follows a specific format. DMX allows for 512 channels each with eight data bits, giving each channel the possibility of 256 values. When a data "Packet" is sent, all channels are transmitted one after another. Even if the data on a specific channel has not been changed, it must be sent. In a packet, a "start code" of all zeros is sent before the data to identify the signal as a Standard DMX transmission. This start code is transparent to the user and is handled by the controller.

The physical signals are transmitted using a twisted pair of wires and a common shield, a configuration called Balanced. The controller and all receiving equipment are connected using a "Daisy Chain" connection. The signal is jumped from the controller to a piece of DMX equipment. From there, the signal is jumped to the next piece of equipment and so on until the last piece of equipment is connected. No branches are allowed and the signal does not come back to the controller. The final piece of equipment will have only one cable connection. As a result, all equipment connected to the chain will see exactly the same signal whether it is first or last. When connecting equipment, no particular attention needs to be paid to the order in which the equipment is connected. Depending on the conditions and equipment, a line terminator may be required. If there is any question, in most circumstances the addition of a terminator will not degrade the signal. To make a terminator, attach a 120-ohm resistor between the Signal Data Negative and Signal Data Positive pins of a connector in the last piece of equipment in the chain.

The DMX Standard uses 5 pin XLR connectors. However, it is common to see fixtures with 3 pin XLR connectors as these types of balanced or "Lo-Z" cables are common in the audio industry. In either case, pin numbers are the same and carry the same signals.

Pin	Connection
1	Common (Shield)
2	Data Negative (S- or Cold)
3	Data Positive (S+ or Hot)
4	n/c (not used)
5	n/c (not used)

Accessory Items (sold separately)

Order Code	Description
CL-MINI/B	MNB Clamp-Mini 3/4"-2"Pipe - Black
CL-CBHALF/LP	Coupler Half Cheese-borough Low Profile - Silver
CL-MICRO/B	MMB Clamp-Micro 7/16" to 1-1/4" OD Pipe Black
DA-DCE1	DC Power Extension Cable - Male to Female connectors, 1.5 meter length (4.92 feet)
DA-DCE3	DC Power Extension Cable - Male to Female connectors, 3 meter length (9.84 feet)
DA-DCE5	DC Power Extension Cable - Male to Female connectors, 5 meter length (16.4 feet)
DA-DCS2	DC 2way Y Splitter Cable - 1 female to 2 males
DA-DCTM	DC Male to Terminal Block Adaptor
CA-XLR5/5	5' DMX 5-pin XLR Cable
CA-XLR5/10	10' DMX 5-pin XLR Cable
CA-XLR5/15	15' DMX 5-pin XLR Cable
CA-XLR5/25	25' DMX 5-pin XLR Cable
CO-XLRTERM3	XLR 3 Pin Data Terminator
CO-XLRTERM5	XLR 5 Pin Data Terminator
CO-XLR3MTO5F	XLR 3 Pin Male to 5 Pin Female Adapter
CO-XLR5MTO3F	XLR 5 Pin Male to 3 Pin Female Adapter
GH-MSCLPM/E	Gobo Holder mSculpt LED Profile Metal Size E - Black
TA-FRAMESCLP268	Color Frame 2.68"x2.68" Square - Black
TA-SCLPMLENS/14	mSculpt Profile Standard Lens Tube 14degree for LED fixtures
TA-SCLPMLENS/19	mSculpt Profile Standard Lens Tube 19degree for LED fixtures
TA-SCLPMLENS/26	mSculpt Profile Standard Lens Tube 26degree for LED fixtures
TA-SCLPMLENS/36	mSculpt Profile Standard Lens Tube 36degree for LED fixtures



10900 Palmbay Drive • Orlando, FL 32824 U.S.A.
www.techni-lux.com