

Halogen FastFit

7019G 750W PGJX50 115V 1CT



Halogen FastFit lamps are replaced in seconds - thanks to the specially designed base. The compact filament ensures high beam intensity, while the shock-resistant design allows easy handling and reliable use in moving head systems. In addition, the highly innovative P3 technology allows use at higher temperatures, which further extends lifetime and consistency of light output. P3 technology also allows the lamp to be used in any burning position and enables more compact designs of fixtures. And because the FastFit design is applied to Philips MSR/MSD Gold™ and Ceramic ST lamps, switching lamp technologies is also quick and easy.

Product data

• General Characteristics

Philips Code	7019G
ANSI Code	-
System Description	P3 Technology
Cap-Base	PGJX50
Bulb Finish	Clear
Filament Shape	Bi-Plane
Operating Position	any
Main Application	Entertainment
Life to 50% failures	300 hr

• Light Technical Characteristics

Color Temperature	3200 K
Technical	
Luminous Flux Lamp	20500 Lm

• Electrical Characteristics

Lamp Wattage	750 W
Voltage	115 V
Dimmable	Yes
Rapid Acting HBC	10 V
Fuse	

• Luminaire Design Requirements

Pinch Temperature	500 (max) C
-------------------	-------------

• Product Dimensions

Overall Length C	140 (max) mm
Diameter D	19 (max) mm
Overall Width E	41 (max) mm
Light Center Length	79 mm
L	
Filament Dimensions (WxH) [mm]	9,5 x 9
Filament Height H	9 mm
Filament Length W	9.5 mm

• Product Data

Order code	924582434428
Full product code	924582434428
Full product name	7019G 750W PGJX50 115V 1CT
Order product name	7019G 750W PGJX50 115V 1CT/10
Pieces per pack	1
Packing configuration	10
Packs per outerbox	10
Bar code on pack - EAN1	8727900807394
Bar code on outerbox - EAN3	8727900807400
Logistic code(s) - 12NC	924582434428
Net weight per piece	130.000 gr

PHILIPS

sense and simplicity

Dimensional drawing

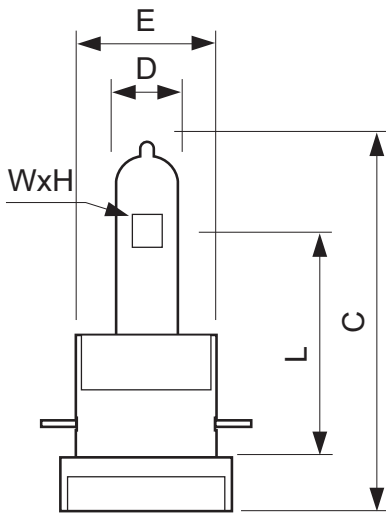

Halogen FastFit

Product	C (Max)	D (Max)	E (Max)	H (Norm)	L (Norm)	W (Norm)
7019G 750W PGJX50 115V FastFit	140	19	41	9	79	9.5

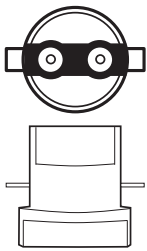

PGJX50

Distributor:



Phone: 407-857-8770
Fax: 407-857-8771
Email: sales@techni-lux.com



© 2012 Koninklijke Philips Electronics N.V.
All rights reserved.

Specifications are subject to change without notice. Trademarks are the property of Koninklijke Philips Electronics N.V. or their respective owners.

www.philips.com/lighting

2012, February 1
data subject to change