

# CSR Lamps

The GE CSR200/DE is a double ended metal halide lamp that provides high efficiency, excellent color rendering, hot restrike capability, and a daylight color temperature. The CSR200/DE is used in the film and event lighting field of entertainment lighting

## Product Description CSR200/DE

•Order Description	CSR200/DE
•Product Code	48450
•Pack Quantity	10
•Rated Wattage	200W
•Rated Voltage	80± V
•Lamp Current (ECG/MCG)*	2.5A
•Ignition Voltage (cold/hot)	5/25(MAX)
•Lumens	16,000 Lm
•Lumens per watt	80
•Ra	>90
•Chromaticity coordinates	x 0.323 y 0.325
•Color temperature	6,000K
•Arc Length	8(MAX)mm
•Lamp length	75MAX
•Light center length	
•Lamp diameter	MAX14
•Average rated life	300hr
•Base	X515

\*ECG = electronic control gear/ MCG = Magnetic control gear

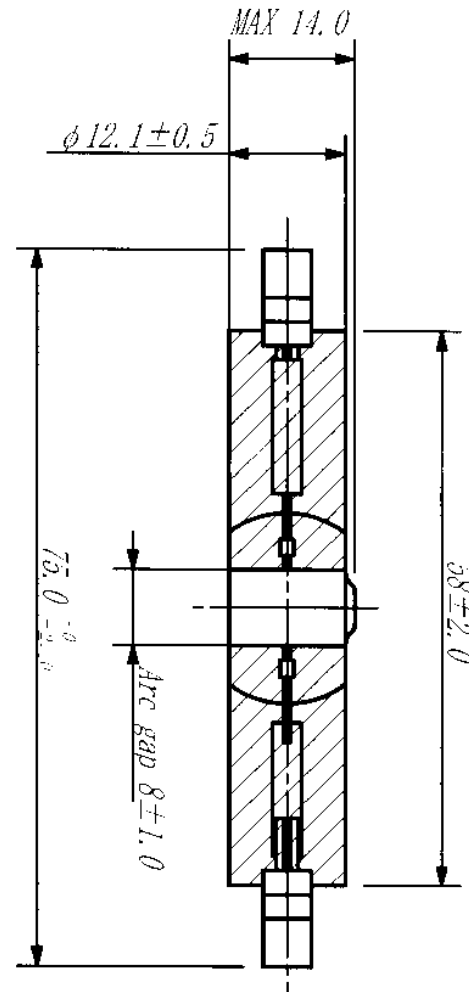

## Lamp Operation

Burn Position	H15
Maximum Seal Temperature	350° C
Cooling	Forced Cooling/Fan
Lamp can be used on electronic or AC magnetic Ballast/igniters	

## Application Information

- Do not exceed rated wattage or voltage
- Replace lamp at or before rated life
- Do not exceed rated seal temperature
- Use only with properly rated fixtures and ballasts

Distributor:



GE imagination at work



Phone: 407-857-8770  
Fax: 407-857-8771  
Email: sales@techni-lux.com